

Laser Glass Processing Solution

P/N: SHR-LGPS-1064-60-10

Three axis laser glass cutting machine, using perfect score technology (PST) and particle swarm optimization (PSO) core technology to ensure high-speed cutting of shaped glass with chipping less than 10um. It has high database integration, accurate and fast to find out the best process parameters. Besides, it has PLC interactive system and easy to adapt to the integration of automated production lines.

Features:

- Reduce cost and increase efficiency
- Stable and reliable equipment
- High speed cutting of shaped glass
- Rapid integration of automated production lines

Laser subsystem in glass cutting:

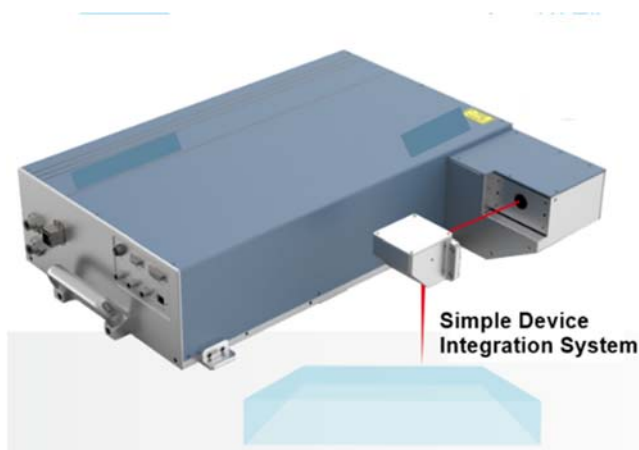

Example of laser cutting system:

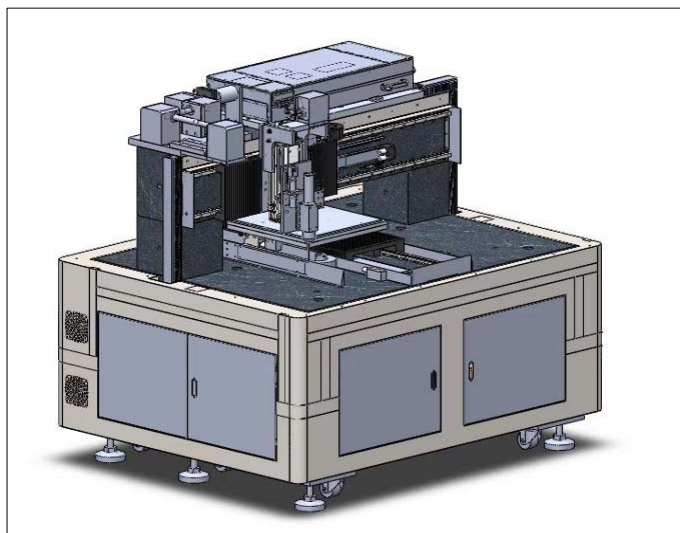
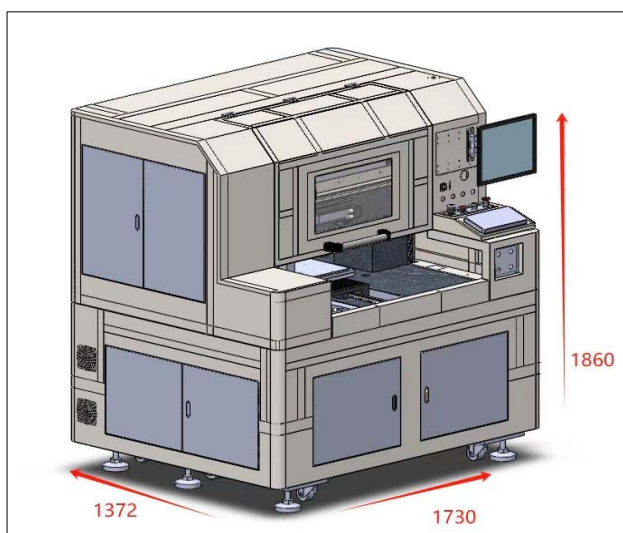

Product parameters:

Laser power	60W/60khz
Laser wavelength	1064nm
Repetition rate	50-300kHz

Drawing file	Support software direct editing drawing, support CAD drawing file importing
Pulse width	10ps
Maximum thickness of cutting	6mm
Spacing accuracy	+/-0.5um
Machining resolution	1um
Amount of chipping	≤10um
Cutting speed	≤300mm/s
Processing width	400mm×600mm (selectable)
Processing acceleration	1g
Machining precision	< 5um
Vision module	expandable
Platform type	Marble table
Axis control	4 control port
Control interface	RS-232/ethernet
Cable length	3m
Cooling method	Water cool
Voltage	AC220V/AC110V, 50Hz/60Hz
Storage temperature	10°C ~ 35°C
Operating temperature	20°C ~ 30°C
Humidity	<60%
Environment dust	<0.20 mg/m ³
Oil mist	Not allow
Weight	~70kg

* The parameters can be customized upon request. Please contact us for more information.

Type of laser beam position:

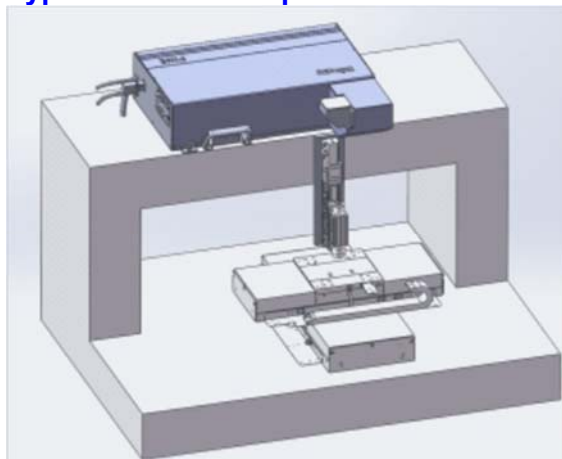

Fixed beam position

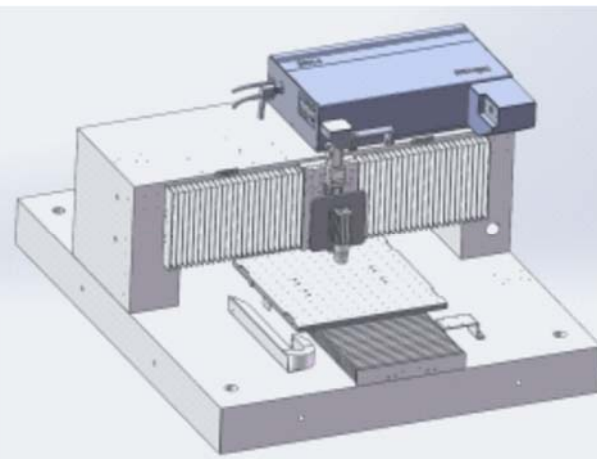

Moving beam position

Software:

PLC automatic programming

- Programmable to interface with upstream and downstream stations on automated production lines

Graphic Editing features

- Compatible with all types of editorial documents
- Automatic optimization of machining paths
- Customizable editing paths

Four axis control

- Output four-axis control signals for rotary cutting

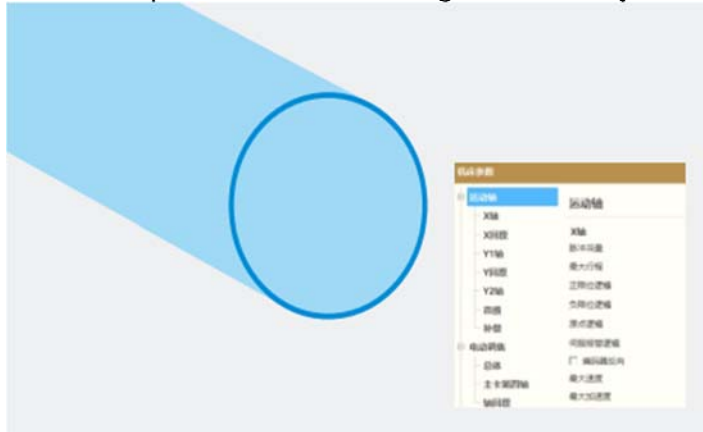

Layered processing function

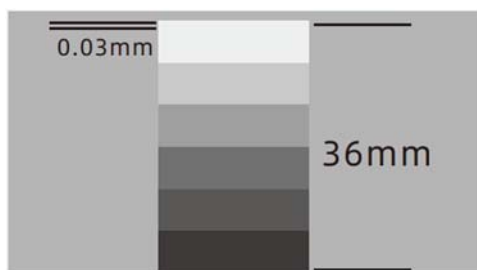

Automatic completion of 6 layer cutting

- Fulfil 0.03-36mm glass cutting
- Actual processing data is affected by the cutting head model

Control interface 4 in 1

- Laser control software
- Platform control software
- Cutting software
- Vision software

Sample display:

