

STVL Series Digital Light Processing (DLP) Subsystems

STVL Series V-Modules

Our V-Modules are fast, flexible, and proven. The cutting-edge performance of these industrial-grade digital light processing (DLP) subsystem is designed for new emerging applications, the DLP subsystems come with a feature-rich programming interface; it will enable impressive capabilities of your new state-of-the-art product within extremely short time-to-market periods. Based on high-speed DLP controllers, DLPC410 (Discovery™4100) and DLPC910, our V-Modules represent the highest performance class of subsystems for the DLP Advanced Light Control portfolio. Our V-Modules offer unique flexibility in mirror control combined with outstanding pattern frequencies thanks to the sustained bandwidth of the DLPCx10 controller chipsets. The usable spectral range covers all wavelengths from 363 nm UVA to 2500 nm NIR. The Type A DMD package provides efficient cooling options enabling up to 160 W sustained optical power transfer per DMD.



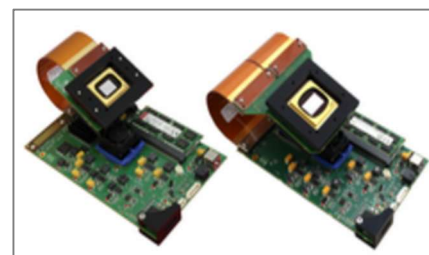

Our V-Modules enable a rapid launch into application development with DLP technology. The modules come with completely configured high-speed FPGA logic and firmware so that customers save time and costs for a dedicated hardware and firmware development. The comprehensive and long-term proven application programming interface ALP-4 is a universal controller suite that provides full software compatibility for all V-Modules. V-Modules are well suited for education, academic research, proof of concept, and are used as OEM DLP subsystems for series production in a wide variety of products.

1. STVL Series SuperSpeed V-Modules

SuperSpeed V-Modules combine maximum on-board data rates and extended on-board memory capacity with an efficient USB 3.0 computer interface. Maximum data throughput is achieved taking advantage of up to 61 Gbit/s sustained data rate of the DLPCx10 controller chipsets.

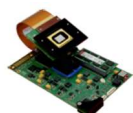

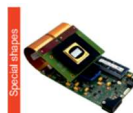
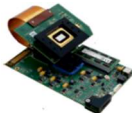
Technical Specification:

Model	STVL-V-7001	STVL-V-7001+	STVL-V-9501 STVL-V-9501C	STVL-V-6501	STVL-V-9001 STVL-V-9001C STVL-V-9001T	STVL-V-650L
Diagram						
Chipset	DLP7000 & DLPC410	DLP7000 & DLPC410	DLP9500 & DLPC410	DLP6500 & DLPC910	DLP9000X & DLPC910	DLP650LNIR & DLPC410
Type A DMD	0.7" XGA	0.7" XGA	0.95" 1080p	0.65" 1080p	0.9" WQXGA	0.65" WXGA
Window Options	VIS, UV	VIS, UV	VIS, UV	VIS	VIS, UV	NIR
Micromirror Array	1 024 x 768	1024 x 768	1 920 x 1 080	1 920 x 1 080	2 560 x 1 600	1 280 x 800
Micromirror Pitch	13.7 µm	13.7 µm	10.8 µm	7.6 µm	7.6 µm	10.8 µm
Active Mirror Array Area	14.0 x 10.5 mm ²	14.0 x 10.5 mm ²	20.7 x 11.7 mm ²	14.5 x 8.2 mm ²	19.4 x 12.1 mm ²	13.8 x 8.6 mm ²
Controller Board Type	V4395	VDIF	V4395	V4390	V4390	V4395
Control Board Dimensions	162 x 99 mm ²	120 x 97 mm ²	162 x 99 mm ²	162 x 99 mm ²	162 x 99 mm ²	162 x 99 mm ²
DMD Board Dimensions	67 x 50 mm ²	48 x 66 mm ²	102 x 83 mm ²	101 x 78 mm ²	95 x 88 mm ²	63 x 47 mm ²
Flexible Cable Length	105 / 283 / 573 mm	44 x 139 mm	105 / 283 / 573 mm	105 / 283 / 573 mm	105 / (283) mm	105 mm

RAM Capacity on Board	64 Gbit / 128 Gbit	64 Gbit / 128 Gbit	64 Gbit / 128 Gbit	64 Gbit / 128 Gbit	64 Gbit / 128 Gbit	64 Gbit / 128 Gbit
Binary Patterns on Board	87381 / 174762	87381 / 174762	31 068 / 62 137	31 068 / 62 137	16 777 / 33 554	55 924 / 111 848
Hardware Trigger	master / slave	master / slave	master / slave	master / slave	master / slave	master / slave
Controller Suite	ALP-4.3	ALP-4.4	ALP-4.3	ALP-4.3	ALP-4.3	ALP-4.3
Max. Switching Rate 1bit B/W	22727 Hz	22727 Hz	17 857 Hz	10 309 Hz	12 987 Hz	10 752 Hz
Max. Switching Rate 6bit Gray	1091 Hz	1091 Hz	987 Hz	871 Hz	1 013 Hz	856 Hz
Max. Switching Rate 8bit Gray	290 Hz	290 Hz	266 Hz	266 Hz	303 Hz	258 Hz
Max. Switching Rate 12bit Gray	18 Hz	18 Hz	17 Hz	17 Hz	20 Hz	17 Hz
PC Interface	USB3.0	USB3.0	USB3.0	USB3.0	USB3.0	USB3.0
PC Transfer Rate	> 4000* fps	> 4000* fps	> 1600* fps	> 1600* fps	> 1100* fps	> 3000* fps
Camera Port	-	2x	-	-	-	-
Camera Cable Length	-	600 / 250 mm	-	-	-	-
Image Sensor (on request)	-	IMX174 (IMX 422 426 536)	-	-	-	-
Controller Suite (Camera Option)	-	DLS-API	-	-	-	-

*Typical value, can vary depending upon data compression ratio and PC.

The block diagram of SuperSpeed V-Modules is as shown below:

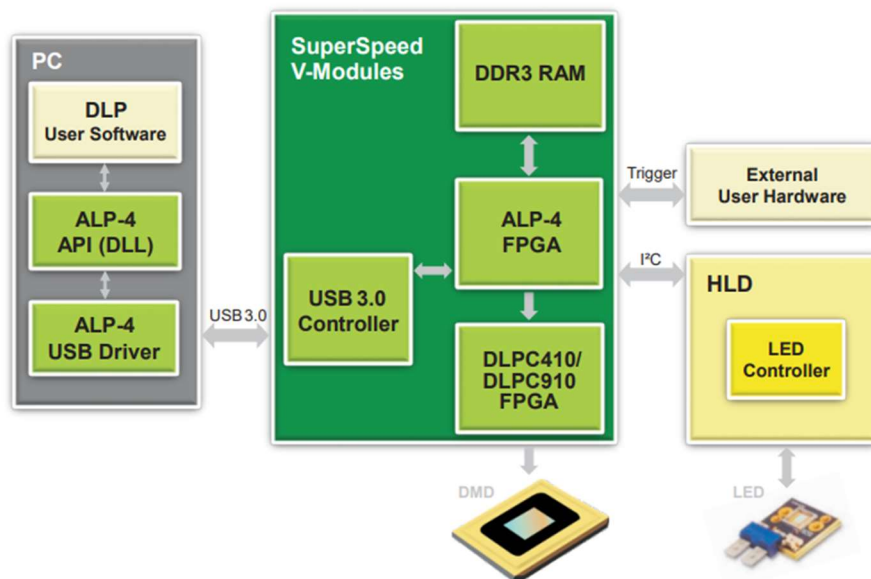

2. STVL Series High Speed V-Module

Hi-Speed V-Modules provide a high-performance package with small form factor. This industrially proven and cost-effective solution supports the DLP7000 chip at its maximum speed of 22 727 global array switches per second. The USB 2.0 computer interface is speeded-up by lossless compression and the on-board memory holds 21 845 binary images. The ALP-4 Controller Suite has the complete functionality and is software compatible with the SuperSpeed V-Modules.

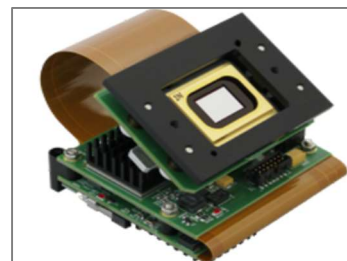

Technical Specification:

Model	STVL-V-7000
DLP chip	Discovery 4100
DMD Type	0.7" XGA 2xLVDS (DLP7000)
Window Options	VIS, UV
Micromirror Array	1024 x 768
Micromirror Pitch	13.7 μ m
Active Mirror Array Area	14.0 x 10.5 mm ²
Controller Board Type	V4100
Control Board Dimensions	71 x 68 mm ²
DMD Board Dimensions	67 x 50 mm ²
Flexible Cable Length	90 mm
RAM Capacity on Board	16 Gbit
Binary Patterns on Board	21845
Hardware Trigger	master / slave
Controller Suite	ALP-4.2
Array Switching Rate 1bit B/W	22727 Hz
Array Switching Rate 1bit B/W	1091 Hz
Array Switching Rate 8bit Gray	290 Hz
PC Interface	USB 2.0
PC Transfer Rate	800 fps*

*Typical value, can vary depending upon data compression ratio and PC.

The block diagram of high-speed V-module is as shown below:

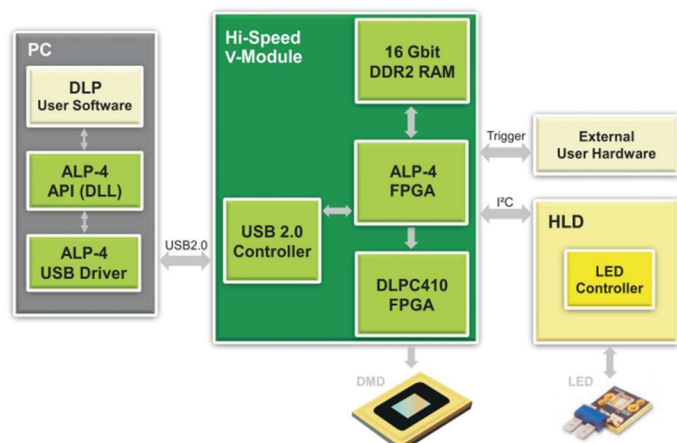

ALP-4 Controller Suite

The ALP-4 Controller Suite is a universal platform enabling advanced control of DLP micromirror systems. Application development is facilitated by an extensive set of library functions designed for use in industry, medicine, research and development. We launched the first ALP Controller Suite TM starting with TI's first DLP Discovery chipsets on the market in 2001. The whole line of FPGA based DLP chipsets has been supported over the years maintaining full compatibility of the application programming interface. Customers using ALP-4 can rapidly launch product design without the need of time-consuming developments for software, firmware and high-frequency FPGA logic code. The scheme of control and data flow is shown in the block diagram (a) below. The principle of operation is completely different from standard multimedia projection. Sequences of patterns are generated in the PC and uploaded to on-board memory via compressed USB transfer. Highly sophisticated FPGA logic is applied for processing and streaming the data to the micromirror array. The ALP-4 Controller Suite is included in all V-Modules, as shown in Diagram (b). It is also available as an accessory for the DLP Discovery4100 evaluation modules (EVM) of Texas Instruments.

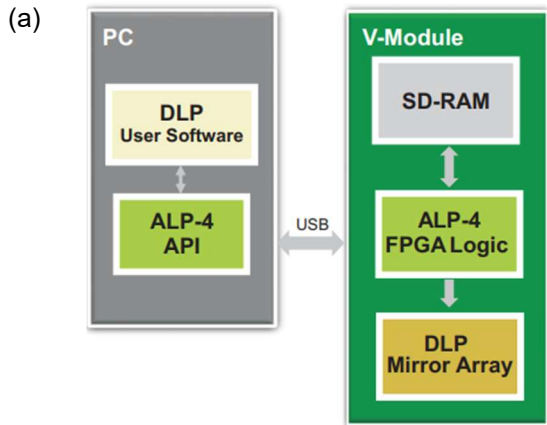

The ALP-4 application programming interface (API) provides high-level DLP control and is a proven tool supporting a wide variety of use cases from proof of concept to product development and serial products. The API is realized in a portable DLL and it can be used in C++, C#, Visual Basic (.NET), Python, MATLAB, LabVIEW, and other development platforms, Python running on a Microsoft Windows operating system.* The ALP-4.3 Controller Suite leverages the power of USB 3.0 SuperSpeed to its full extend and increases the effective transfer rate by lossless compression of patterns. Low latency updates of the micromirror array enable feedback operations via PC with ≤ 1.5 ms refresh cycle period.

The broad usability of the ALP-4.3 Controller Suite is powered by the high flexibility in pattern control. Pattern sequences can be customized in ALP-4.3 to meet respective requirements and four different modes of operation are available.

Binary Patterns

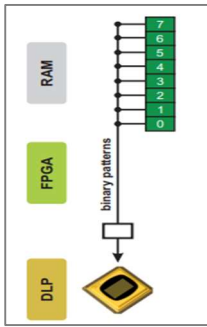

Binary pattern sequences are defined in the application program and uploaded into the on-board RAM. The timing parameters for the sequence display can be precisely controlled. ALP-4 offers high flexibility in picture time ranging from 20 μ s up to several seconds. That means, mirrors can be kept still without any movement or can be switched with up to 50kHz. A comprehensive trigger facility enables the synchronization with external devices in both master or slave mode. Multiple sequences are organized in a queue for convenient parallel upload and display and are concatenated for a gapless display.

Grayscale Patterns

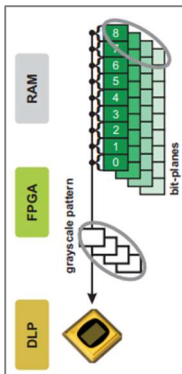

By design, the DMD is only capable to display a binary pattern at a given moment in time. To project a grayscale image, multiple binary frames have to be time controlled accordingly. ALP-4 generates patterns of gray values with the digital precision of FPGA timing. The maximum bit-depth is 12bit; lower resolution can be selected. Using a synchronized detector yields perfect grayscale linearity of 10 ppm as it is typically needed in metrology applications of DLP. The grayscale pattern sequence contains the specified number of bit-planes and an efficient algorithm of pulse-width modulation (PWM) is implemented in ALP-4 that results in 260-300 fps (8 bit) for various DLP chipsets. The whole grayscale image is subject to the trigger facility so that cameras can be easily synchronized. Flex-PWM is an advanced mode of operation where the user has free control over the bit-plane timing by external trigger.

Pattern Sequence Composition

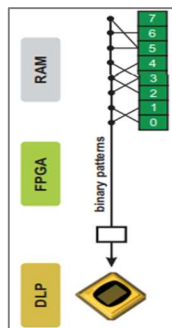

ALP-4 supports indirect frame selection by the use of a frame look-up table (FLUT). The output display sequence is composed from the patterns stored in the RAM using the FLUT entries that point to the corresponding frames. In this way the user has a maximum of flexibility in generating display sequences and can modify them by just changing the FLUT content. Repeated display of the same pattern is made possible without storing multiple copies in the RAM so that FLUT operation saves upload time and memory capacity. One of the FLUT applications is grayscale encoding by a delta-sigma approach.

Pattern Scrolling

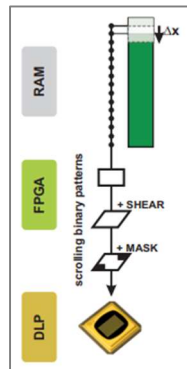

A moving DLP exposure head is state-of-the-art in industrial exposure applications like lithography and 3D-printing. Such approach requires that the patterns slide through the micromirror array with the same velocity. That is efficiently realized by uploading the stripe of pattern data to the RAM and stepping through it line by line. In this way a new DLP pattern is generated in each step by adding one line and dropping another. A significant data reduction is achieved for the upload from PC to on-board RAM. More sophisticated use cases demand for a sliding display of rotated patterns; that has been solved by additional shear operations applied on the flight. Permanent pixel masks are supported enabling modifications of the resulting pattern exposure level on the target.

Features of ALP Controller Suite

- **Vertical scrolling:** The ALPAPI supports linearly stepping through multiple concatenated frames by an arbitrary number of rows.
- **Use case:** Faster and more efficient use of board memory for Lithography and 3D printing applications.
- **Horizontal shearing:** The frame can be sheared in horizontal direction (line based) by a configurable value without modifying the frame data.
- **Use Case:** Generate a rotated image on the DMD by applying an additional shearing in vertical direction with preprocessing.
- **DMD mask:** The DMD Mask is a monochrome bitmap that overlays ALP frames during frame display. The affected position is fixed on the DMD.
- **Use Case:** Horizontally shape the exposure energy when scrolling vertically through a sequence of frames
- **Frame lookup table:** Besides linear display of a sequence of frames, the ALP supports random-access order via Look up Table. Images are fully loaded only once.
- **Use Case:** Flexible selection of projection images with low latency, as only the information of image order is loaded.
- **DMD area of interest:** The ALP API supports an additional display mode with reduced image data. An Area of Interest (AOI) can be selected by means of contiguous DMD rows.
- **Use Case:** Support of an increased framerate / Improved speed.
- **Concatenation of frames for continuous projection:** Multiple frames can be combined into one sequence.
- **Use Case:** Displaying images continuously without any break between the projection of two consecutive images.
- **Projection control by external trigger (slave mode):** The transition to the next projection frame can be triggered and synchronized by an external signal.
- **Use Case:** Chaining of several projectors or V-Modules.
- **Multiple customizable frame synchronization outputs:** Up to three customizable synchronization signals can be generated and outputted by the V-Module.
- **Use Case:** Trigger and synchronize external hardware, for instance as multi color light source.
- **PWM output:** V-Modules support this with a pulse-width modulated GPIO pin (analog signal)
- **Use Case:** Controlling a light source with an analog signal.

STVL Series Industrial Grade DLP Projection

1. STVL Series Single-Color Industrial Pattern Projection, STVL-07-2.0-UV/VIS

Option: UV, VIS

STVL-07-2.0-UV/VIS is a high performance DLP® projector based upon the Texas Instruments micromirror technology and designed to serve in demanding industrial applications. Widely used in multimedia and digital cinema since more than one decade, the well proven DLP technology has become an important tool for industrial solutions as well. The heart of this projector is a 0.7" DLP chip that consists of an array of 1024x768 mirrors. These bi-stable mirrors flip into opposite tilt positions within microseconds to generate the desired patterns. STVL-07-2.0-UV/VIS provides precise high-speed control for each individual mirror enabling outstanding flexibility and pattern frame rates of the projection output. The projector is equipped with a high-power LED light source that is the key for the compact and rugged design of the device. Typical use cases are machine vision illumination, 3D scanning, industrial exposure, and additive manufacturing. Beyond that, new emerging applications are well supported by an open SDK interface. STVL-07-2.0-UV/VIS comes with two lens options, the standard projection lens and a wide-angle lens with fixed focal length.



System Architecture

The central control unit of STVL-07-2.0-UV/VIS is USB 2.0 connected and realizes pattern upload, display, and synchronization. An integrated trigger facility supports a wide voltage range at its opto-coupler interface and is software programmable. The digital driver for the LED light source gives convenient access to power setting and temperature reading for thermal management.

System Control

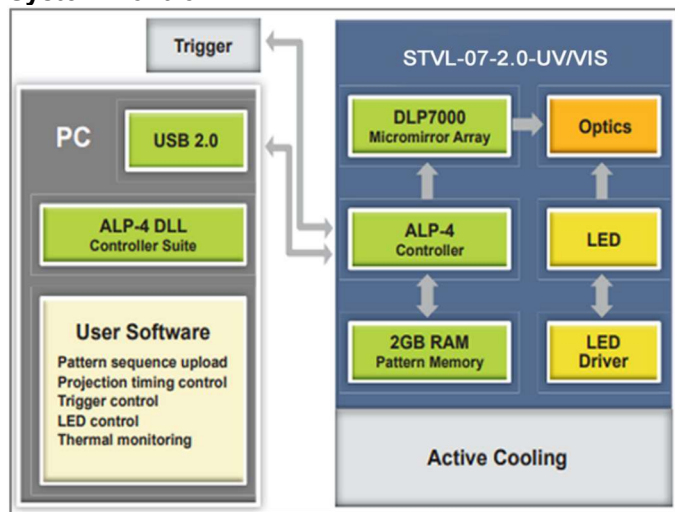

The ALP-4.2 Controller Suite is the central programming tool and provides all necessary functionality for product development. Sequences of patterns are uploaded from PC to the on-board memory via USB 2.0 transfer with lossless compression. The properties of the display sequences, e.g., bit depth, picture time, trigger mode, repetitions can be freely defined to meet the respective application requirements. The ALP-4.2 firmware streams patterns from on-board SDRAM memory to the DLP7000 micromirror array where the input pattern is one-to-one mapped to the mirrors. The patterns are updated in the global reset mode; that means all mirrors are switching simultaneously within a few microseconds. Grey value patterns are generated by controlled ON-time for each mirror yielding exact grey value linearity. The maximum global array switching rate is 22 727 fps; even higher frame rates up to 50 kHz can be achieved by partial updates of the micromirror array. Multiple STVL-07-2.0-UV/VIS devices can be run in parallel, conveniently controlled from the same application program and precisely synchronized by the trigger facility. The ALP-4.2 API is well proven and the DLL supports C++, C#,

Visual Basic (.NET), Python, MATLAB, LabVIEW, and other development platforms. Microsoft® operating systems are supported up to the most recent Windows® versions both, 32-bit and 64-bit. The ALP-4 USB 2.0 driver is robust, validated, UIF compliant and 24/7 proven in industrial and medical use.

Specifications

LED options

	RED	GREEN	BLUE	VIOLET	WHITE
Typical dominant wavelength	613nm	525nm	460nm	405nm	-
Spectral bandwidth FWHM	19nm	34nm	20nm	20nm	-
STVL-07-2.0-UV/VIS output*	330lm 1450mW	850lm 1550mW	140lm 2550mW	- 2150mW	1100lm -

* Typical value for continuous projection, pulse operation may yield higher output.

Lens options

	Mass	Distortion	Working distance	Throw ratio	Uniformity (IEC)	Contrast FOFO	MTF
Standard lens	123 g	0.2%	0.4m – 10m	1.8	+35%/-30%	2000:1	45% @ 36 lp/mm
Wide angle lens	580	5.5	0.5m – 2m	0.9	+26%/-23%	2000:1	30% @ 36 lp/mm

Frame rates

DMD array (AOI)	1024 x 768	1024 x 768	1024 x 768	1024 x 768	1024 x 768	1024 x 512
Bit depth	8-bit	7-bit	6-bit	5-bit	1-bit	1-bit
Frame rate	290 fps	569 fps	1091 fps	2016 fps	22727 fps	30300 fps

Greyscale linearity

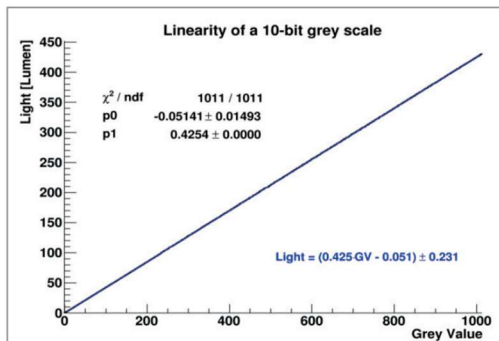

ALP-4 supports precise bit-plane timing enabling outstanding greyscale linearity in connection with synchronized camera recording. Grey value deviations are < 0.06 % of the full-scale value.

General

Mass (without lens)	Input power	Operating temperature	Storage temperature	Regulations	LED lifetime
2000 g	DC 12-24 V 150W	10°C to 40°C Non-condensing	-10°C to 50°C Non-condensing	CE FCC Class A	>10000 h (ON time)

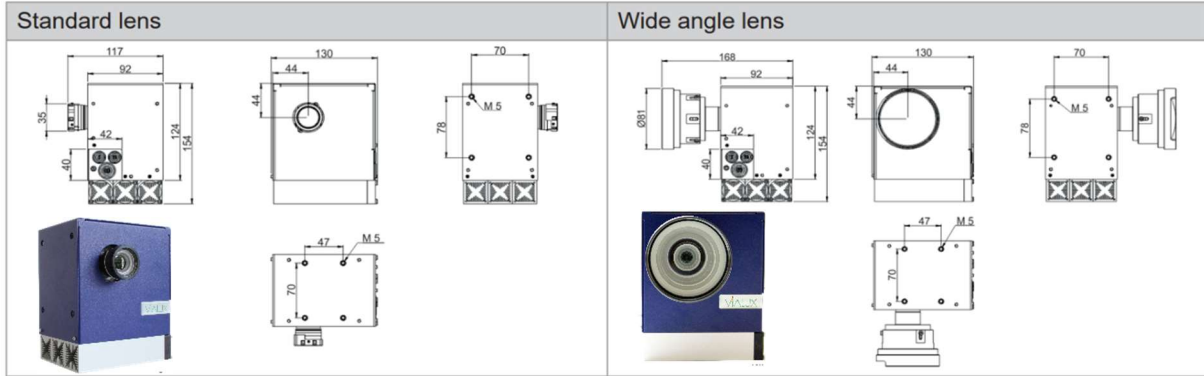
Dimension (mm)

2. STVL Series Multi-Color Industrial Pattern Projection, STVL-07-2.0-RGB

The STVL-07-2.0-RGB projector, option RGB, is equipped with three high-power LED light sources and an integrated cooling system. Typical use cases are 3D volumetric display, 3D measurement, augmented reality applications, and machine vision illumination. Beyond that, new emerging applications are well supported by an open SDK interface. STVL-07-2.0-RGB comes with two lens options, the standard projection lens with zoom capability and a wide-angle lens with fixed focal length.

System Architecture

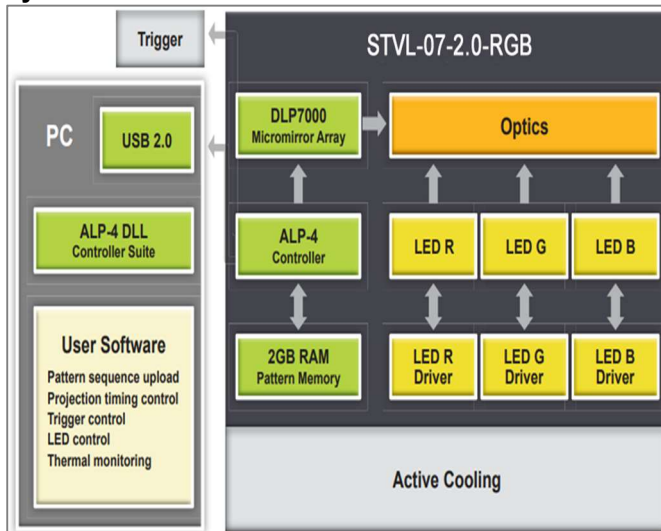
The central control unit of STVL-07-2.0-RGB is USB 2.0 connected and realizes pattern upload, display, and synchronization. An integrated trigger facility supports a wide voltage range at its opto-coupler interface and is software programmable. The digital driver for the LED light source gives convenient access to power setting and temperature reading for thermal management.

System Control

The ALP-4.2 Controller Suite is the central programming tool and provides all necessary features for advanced product development. Sequences of patterns are uploaded from PC to the on-board memory via USB 2.0 transfer with lossless compression. The STVL-07-2.0-RGB is USB 2.0 connected and realizes pattern upload, display, and synchronization. Three individual digital drivers for the three LED light sources give convenient access to power setting and temperature reading for thermal management of each single LED. In addition, each LED is gated by a programmable high-speed control line. An integrated trigger facility supports selectable voltage levels for external master or slave modes of control. The properties of the display sequences, e.g., bit depth, picture time, trigger mode, repetitions can be freely defined to meet the respective application requirements. The ALP-4.2 firmware streams patterns from on-board SDRAM memory to the DLP7000 micro mirror array where the input pattern is one-to-

one mapped to the mirrors. The patterns are updated in the global reset mode; that means all mirrors are switching simultaneously within a few microseconds. Grey value patterns are generated by controlled ON-time for each mirror yielding exact grey value linearity. The maximum global array switching rate is 22 727 fps. Multiple STVL-07-2.0-RGB devices can be run in parallel, conveniently controlled from the same application program and precisely synchronized by the trigger facility. The ALP-4.2 API is well proven and the DLL supports C++, C#, Visual Basic (.NET), Python, MATLAB, LabVIEW, and other development platforms. Microsoft® operating systems are supported up to the most recent Windows® versions both, 32-bit and 64-bit. The ALP-4 USB 2.0 driver is robust, validated, UIF compliant and 24/7 proven in industrial and medical use.

Optical and thermal design



The red, green, and blue light output of each LED is combined and fed into the homogenizer (light tunnel) by means of a dichroic mirror system. The output color of STVL-07-2.0-RGB can be RGB switched with the full frame rate. A common copper heat sink with an active cooler is included for the thermal management of the LED light sources. The temperature monitoring facility of ALP-4.2 provides all the information needed to guarantee safe LED operation within the specified limits.

Specification

LED Options

	RED	GREEN	BLUE
Typical dominant wavelength	613nm	525nm	460nm
Spectral bandwidth FWHM	19nm	34nm	20nm
STVL-07-2.0-RGB output*	400lm 1750mW	850lm 1550mW	140lm 2550mW

* Typical value for continuous projection, pulse operation may yield higher output

Lens options

STVL-07-2.0-RGB	Length L Diameter D Mass M	Distortion	Working distance D Throw ratio TR
Standard lens Part No: 9052	L=40mm D=35mm M-120g	0.2%	D> 0.4m TR =1.8...2.1
Wide angle lens Part No: 9591	L=91mm D=81mm M-580g	5.5%	D> 0.5m TR = 0.9

Frame rates per color

DMD array (AOI)	1024 x 768	1024 x 768	1024 x 768	1024 x 768	1024 x 768	1024 x 512
Bit depth	8-bit	7-bit	6-bit	5-bit	1-bit	1-bit
Frame rate	290 fps	569 fps	1091 fps	2016 fps	22727 fps	30300 fps

General

Mass (without lens)	Input power	Operating temperature	Storage temperature	Regulations	LED lifetime
3200 g	DC 12-24 V 150W	10°C to 40°C Non-condensing	-10°C to 50°C Non-condensing	CE FCC Class A	>10000 h (ON time)

Dimensions (mm)

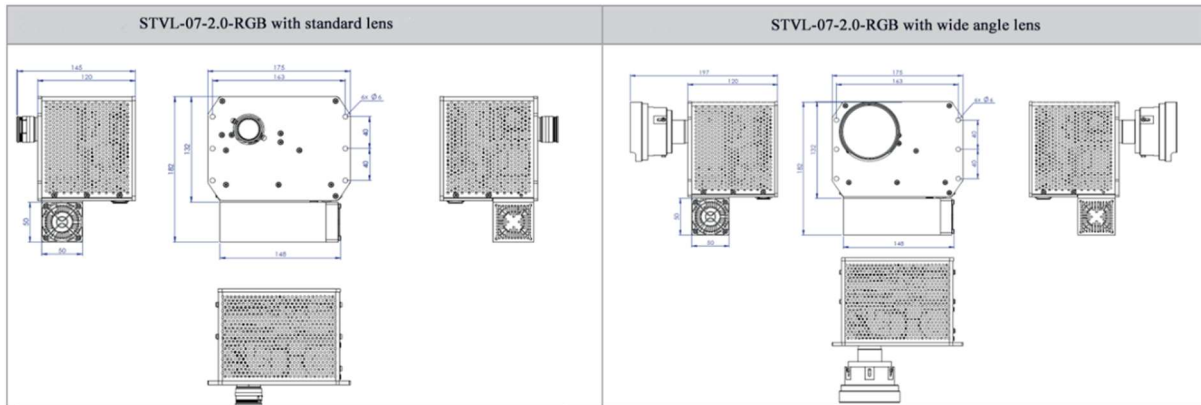

3. STVL Series Industrial Pattern Projection, STVL-07-3.0-UV/VIS/RGB

Option: UV, VIS, RGB

STVL-07-3.0-UV/VIS/RGB is a high performance DLP® projector based upon the Texas Instruments micromirror technology and designed to serve in demanding industrial applications. Widely used in multimedia and digital cinema since more than 20 years, the well proven DLP technology has become an important tool for industrial solutions as well. The heart of the STVL-07-3.0-UV/VIS/RGB projector is a 0.7" DLP chip that consists of an array of 1 024x768 mirrors. These bi-stable mirrors flip into opposite tilt positions within microseconds to generate the desired patterns. STVL-07-3.0-UV/VIS/RGB provides precise high-speed control for each individual mirror enabling outstanding flexibility and pattern frame rates of the projection output. The projector is equipped with a high-power LED light source that is the key for the compact and rugged design of the device. Typical use cases are machine vision illumination, 3D scanning, industrial exposure, and additive manufacturing. Beyond that, new emerging applications are well supported by an open SDK interface. STVL-07-3.0-UV/VIS/RGB comes with two lens options, the standard projection lens with zoom capability and a wide-angle lens with fixed focal length.



System Architecture

The central control unit of STVL-07-3.0-UV/VIS/RGB is USB3.0 connected and realizes pattern upload, display, and synchronization. An integrated trigger facility supports selectable voltage levels and is software programmable. The digital driver for the LED light source gives convenient access to power setting and temperature reading for thermal management.

System Control

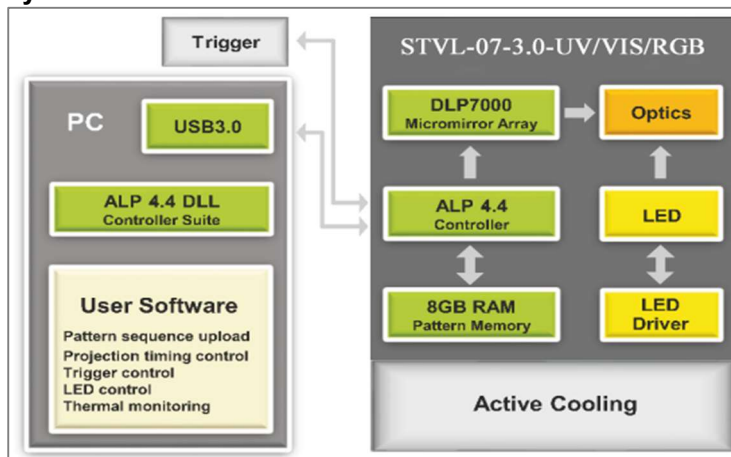

The ALP-4.4 Controller Suite is the central programming tool and provides all necessary functionality for product development. Sequences of patterns are uploaded from PC to the on-board memory via USB3.0 transfer with lossless compression. The properties of the display sequences, e.g., bit depth, picture time, trigger mode, repetitions can be freely defined to meet the respective application requirements. The ALP-4.4 firmware streams patterns from on-board SDRAM memory to the DLP7000 micro mirror array where the input pattern is one-to-one mapped to the mirrors. The patterns are updated in the global reset mode; that means all mirrors are switching simultaneously within a few microseconds. Grey value patterns are generated by controlled ON-time for each mirror yielding exact grey value linearity. The maximum global array switching rate is 22 727 fps; even higher frame rates can be achieved by partial updates of the micromirror array. Multiple STVL-07-3.0-UV/VIS/RGB devices can be run in parallel, conveniently controlled from the same application program and precisely synchronized by the trigger facility. The ALP-4.4 API is well proven for all DLPC410 chipsets; the DLL supports C++, Python LabVIEW, .NET and other development platforms. Microsoft® operating systems are supported up to the most recent Windows® versions both, 32-bit and 64-bit. The ALP-4 USB3.0 driver is robust, validated, UIF compliant and 24/7 proven in industrial and medical use.

Specifications

LED Options

	RED	GREEN	BLUE	VIOLET	WHITE
Dominant wavelength	613**nm	525nm	460nm	405/385*/365*nm	-
Spectral bandwidth FWHM	19nm	34nm	20nm	15nm	-
STVL-07-3.0-RGB output*	330lm 1450mW	850lm 1550mW	140lm 2550mW	- 1750/2450/2550mW	1100lm -

*Not available in STVL-07-3.0-RGB

** 635nm available on request

*** Typical value for continuous projection, pulse operation may yield higher output

Lens options

	Length L Diameter D Mass M	Distortion	Working distance D Throw ratio TR	Zoom	Uniformity (IEC) Contrast FOFO	MTF
Standard lens	L=36mm D=35mm M-150g	0.2%	D> 0.4m TR =1.8...2.1	1.00- 1.16	+25%/-30% 2000:1	45% @ 36 lp/mm

Frame rates

DMD array (AOI)	1024 x 768	1024 x 768	1024 x 768	1024 x 768	1024 x 768	1024 x 512
Bit depth	8-bit	7-bit	6-bit	5-bit	1-bit	1-bit
Frame rate	290 fps	569 fps	1091 fps	2016 fps	22727 fps	30300 fps

Greyscale linearity

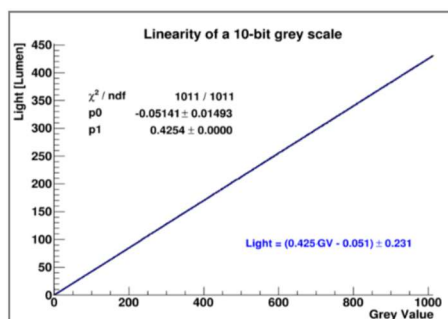

ALP-4 supports precise bit-plane timing enabling outstanding greyscale linearity in connection with synchronized camera recording. Grey value deviations are < 0.06% of the full-scale value.

General

Mass (without lens)	Input power	Operating temperature	Storage temperature	Regulations	LED lifetime
3000 g	DC 19-24 V 150W	10°C to 40°C Non-condensing	-10°C to 50°C Non-condensing	CE FCC Class A	>10000 h (ON time)

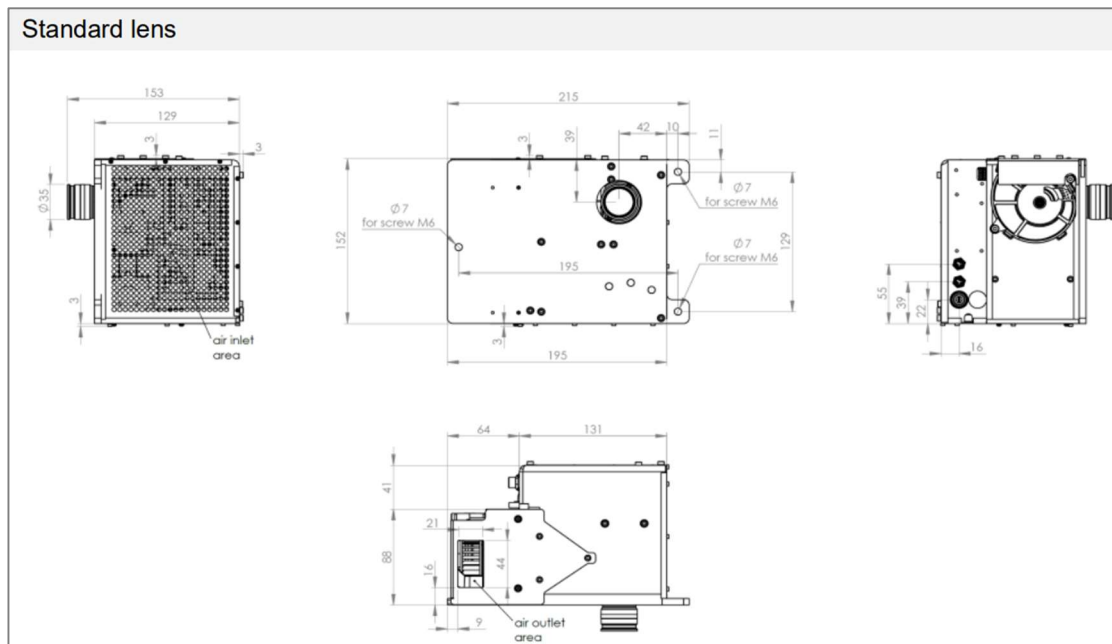
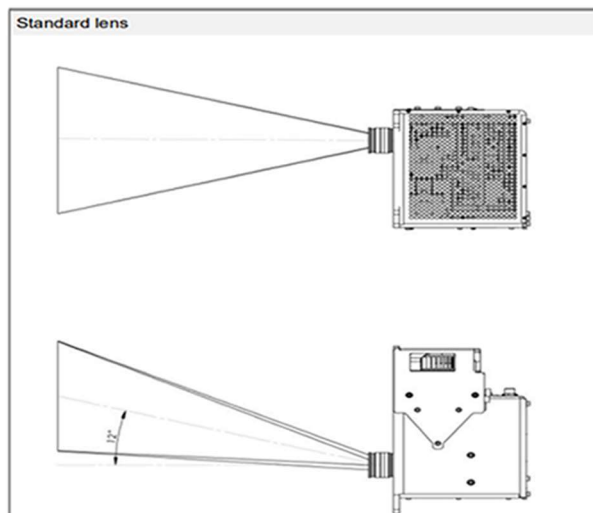
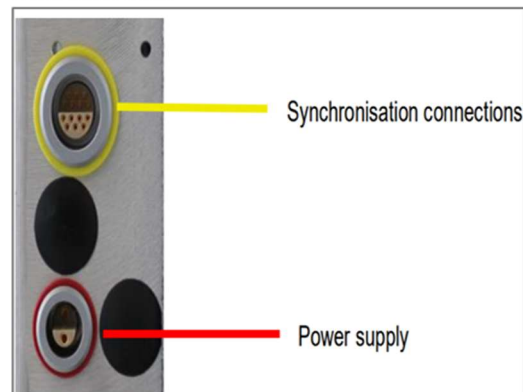
Dimensions [mm]

Lens shift

Connections

Synchronization:

Pin	Signal	I/O	Limit	Description/ Usage
1	Dynamic Frame Trigger	Out	5V, 10mA	outputs a dynamic frame trigger (ALP Extension DYN_SYNCH_OUT)
2				not connected
3	Frame Trigger	Out	5V, 10mA	outputs one pulse per frame, e.g., for synchronizing a slave projector/camera; ALP API commands: • AlpSeqTiming (SynchDelay, SynchPulseWidth): relation to frame timing • AlpDevControl (ALP_SYNCH_POLARITY)
4				not connected
5				not connected
6	DC 5V +	Out	5V, 350mA	supply voltage
7				not connected
8				not connected
9				not connected

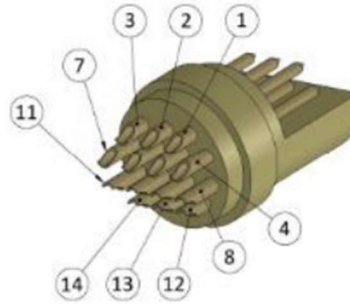
10	DC 5V GND	GND		supply voltage ground
11				not connected
12				not connected
13				not connected
14	Frame Trigger	In	5V	triggers next frame in sequence, e.g. for synchronization with a master projector/camera ALP API commands: • AlpProjControl: ALP_PROJ_MODE=ALP_SLAVE • AlpSeqTiming (TriggerInDelay): relation to frame timing • AlpDevControl (ALP_TRIGGER_EDGE)



Lemo plug internal, soldering side



Lemo plug FFA.2C.314.CLAC

Connector: Lemo FFA.2C.314.CLAC52Z with yellow bend relief Lemo:GMA.1B.045.DJ
Cable: 7x0,14 mm² multiconductor shielded cable, grey, diameter 5.0 mm, Lemo: 070140

Power supply:

Pin	Signal	Description / Usage
1	GND	Ground
2	+19...24 V	Positive power supply



Connector: Lemo FFA.1S.302.CLAK82Z with red bend relief Lemo:GMA.2B.070.DR
Cable: 2x0,5 mm² (AWG20) with shield, diameter 7,2 ... 8,2 mm
Power supply unit (Example): XP-Power AHM150PS19
USB 3.0: Use only USB3.0 cable with high quality, Maximum cable length 3 m

4. STVL Series Monochrome LED Projection module, STVL-3.0-EVM-UV/VIS/NIR

Option: UV, VIS, NIR

STVL-3.0-EVM-UV/VIS/NIR monochrome LED light engine is a high performance DLP® projector based upon the Texas Instruments micromirror technology and designed to serve in demanding industrial or research applications.

STVL-3.0-EVM-UV/VIS/NIR is available with the following V-Modules:

- STVL-V-6501 VIS
- STVL-V-650L NIR
- STVL-V-7001 VIS/UV

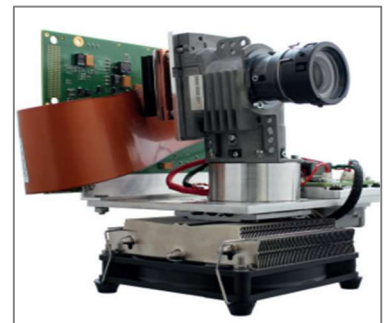

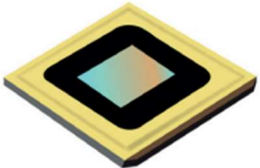
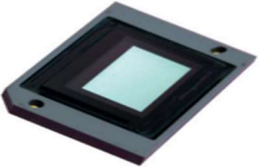
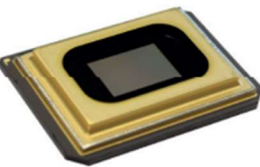
	<p>The STVL-V-6501 VIS is based on a 0.65" 1080p DLP chip (DLP6500) and the DLPC910 controller enabling binary pattern rates up to 10 309 Hz in the visible range (400 - 700 nm) with a light power density up to 25 W/cm²</p>
	<p>Featuring a 0.65" WXGA DLP chip (DLP650LNIR) and the DLPC410 controller the STVL-V-650L NIR supports binary pattern rates up to 10752 Hz in near-infrared range (800 - 2000 nm) with light power density up to 500 W/cm² between 950 nm - 1150 nm.</p>
	<p>With its 0.7" XGA DLP chip (DLP7000/DLP7000UV) and the DLPC410 controller the STVL-V-7001 VIS/UV creates binary patterns up to 22 727 Hz in the visible range (400 - 700 nm) or alternatively in the ultraviolet-range (363 - 420 nm).</p>

System Architecture

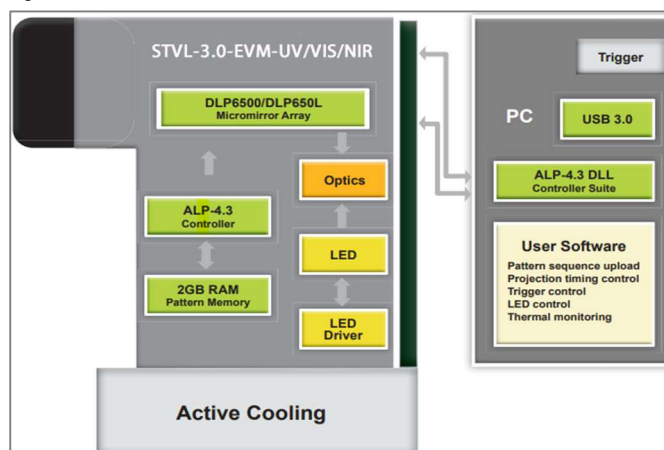

The central control unit of STVL-3.0-EVM-UV-VIS/NIR is USB 3.0 connected and realizes pattern upload, display, and synchronization. An integrated trigger facility supports a wide voltage range at its opto-coupler interface and is software programmable. The digital driver for the LED light source gives convenient access to power setting and temperature reading for thermal management.

STVL-3.0-EVM-UV/VIS/NIR monochrome LED light engines are based upon the STAR CORE optics, a cooling system, the ALP-4.3 software, and integrate a high-power LED including the LED driver for up to 24 A.

The following LED wavelengths are available for:

- λ [nm] = 405 / 460 / 525 / 615 / White (DLP6500)
- λ [nm] = 730 / 850 / 940 (DLP650LNIR)
- λ [nm] = 405 / 460 / 525 / 615 / White (DLP7000)
- λ [nm] = 365 / 385 / 405 (DLP7000UV)

The LED driver of STVL-3.0-EVM-UV/VIS/NIR is controlled by I²C commands for setting the LED current and reading the LED thermistor output and seamlessly integrates with our V-Modules.

Dimensions of STVL-3.0-EVM-UV/VIS/NIR [mm]
with SuperSpeed STVL-V-650L NIR (as an example)

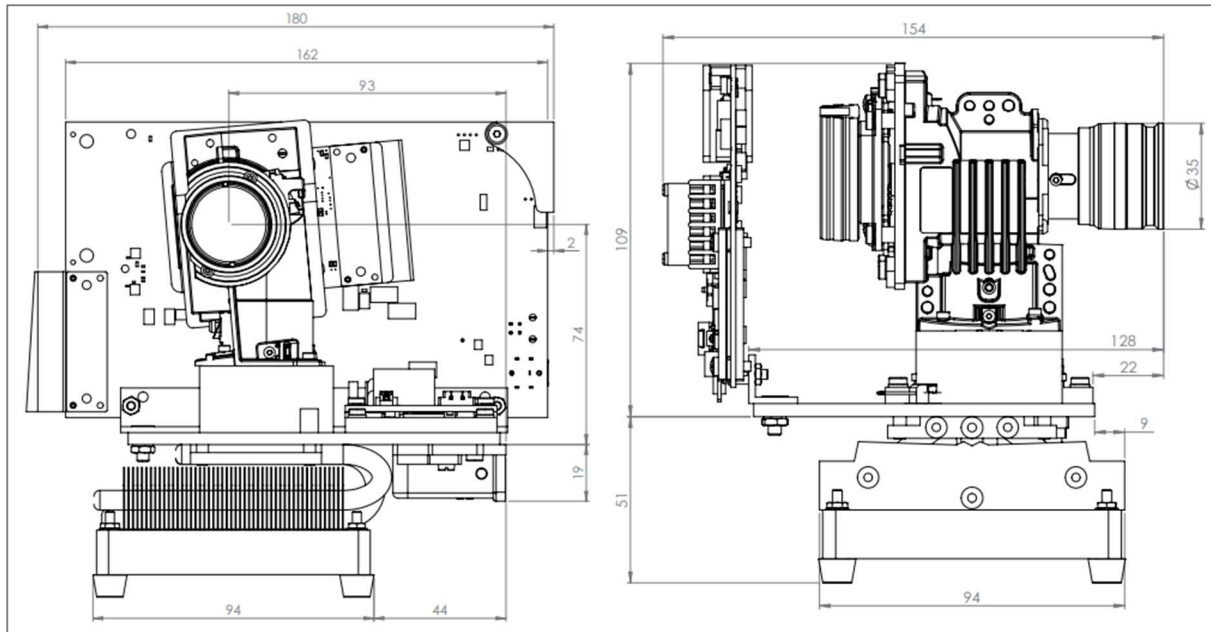

Power supply

STVL-3.0-EVM-UV/VIS/NIR comes with its own power supply designed for the LED driver with a maximum output of 24 A DC.

Specifications:

Input 100 – 240 V ~ 2 A, 50 – 60 Hz Output 19 V / 7.89 A

STVL Series 3D Imaging Scanner

STVL Series Direct Link Sensor DLS-Module

A Marriage of Projector and Camera for Next Generation Imaging Solutions



The success of digital image processing solutions depends on both, the imaging device and appropriate illumination. Frequently, specifically structured light patterns are required and @DLP micro-mirror projection turned out to be fast, flexible and proven for that purpose. Multiple different devices, projectors and cameras, used to be combined for pattern generation and image sensing. Such setups cause challenges for precise synchronization and computer interfacing. We have linked together the image sensor chips and the DLP micro-mirror device into the same electronic control circuitry resulting in ONE integrated device. This Direct Link Sensor (DLS) represents a new class of imaging tools enabling advanced vision solutions.

DLS Principle of Operation

Our FPGA logic controls both the high-performance DLP chip for fast and precise pattern projection and the image sensors for digital imaging. In that way pattern generation and image recording are precisely synchronized, also for partial sensor readout in a region of interest. Frame rates vary from 166 fps to 5150 fps (ROI) for each camera in parallel. The schematic below shows the DLS architecture with the major data flow.

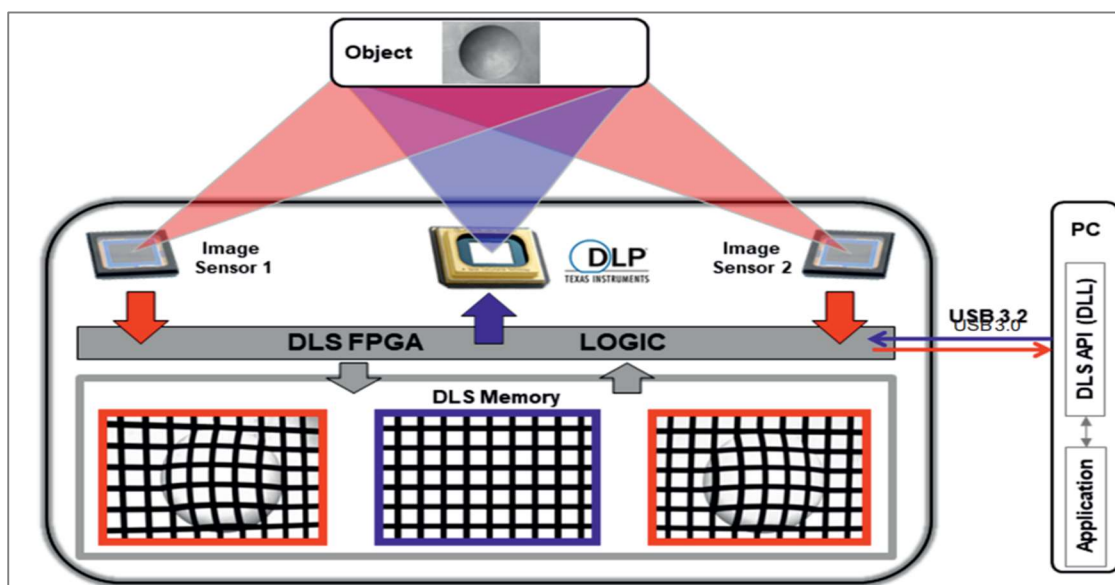

A sequence of user-defined projection patterns is uploaded into the DLS memory (RAM) and the data can be used for a single projection or for a projection loop. The illuminated object is recorded by the sensors and the images are buffered in the on-board RAM that holds up to 1592 pictures (10 bit, 1920 x 1200 pixels), ready for download to the PC for further processing. All data flow operations are executed by one FPGA device enabling the outstanding real-time precision. Streaming data to and from the on-board RAM is realized by the USB3.0 SuperSpeed transfer implemented on the DLS system. The upload is further enhanced by lossless on the fly compression and pixel binning is available as an option for image download.

A custom application program controls the DLS system through the DLS API, an application development interface supporting rapid system development. The DLS API is implemented as a dynamic-link library (DLL) and the functions are designed to build an application with a minimum of programming effort providing maximum control capabilities at the same time. The user can define any type of pattern sequence that may differ in bit depth, number of pictures, and frame rate. The DLS principle of operation offers significant advantages for machine vision applications requiring flexible scene illumination:

- Projection and imaging components are precisely synchronized
- High bandwidth transfers are running independent from PC
- Hardware integration guarantees real-time data flow
- The DLS-Module requires only one USB3.0 interface
- The clear API software facilitates rapid application development

Specifications of DLS system

DLP projection chipset			
DLP7000 micro-mirror array, 1024 x 768 mirrors			
Max. pattern update rate, 22727 fps (full array)			
Image sensor chip			
Sony Pregius IMX-174, 1920 x 1200 pixels			
Max. image buffer capacity, 1592 full resolution, 10 bit images.			
DLS frame rates (selected regions of interest – ROI)			
Image sensor lines (ROI)	DLS frame rate	Image sensor bit depth	DLP projector bit depth
1200	166fps	10 bit	8 bit
676	289 fps	10 bit	8 bit
374	500 fps	10 bit	7 bit
236	750 fps	10 bit	6 bit
168	1000 fps	10 bit	6 bit
70	1900 fps	10 bit	5 bit
2	5150 fps	10 bit	2 bit

Models

The STVL-DLS-1 and STVL-DLS-2 Modules address different field of view and working distance (WD), respectively. The diagonal field of view (DFOV) is given by $DFOV = 0.69 \times WD$. The STVL-DLS-1. The STVL-DLS-2 Industrial Module is a version of STVL-DLS-2 Module. The STVL-DLS-2 Industrial Modules is equipped with a dust-proof housing and passive cooling for industrial use cases. Long lasting high-power LEDs form the light source for the two DLS-Modules.





An additional software package zSnapper SDK (zSn.dll) is available as an optional extension for our DLS-Modules enabling high-speed and high-precision 3D coordinate acquisition. This powerful 3D measurement software has been developed for our 3D scanners and is now released on module level. It delivers (x, y, z) coordinates directly and automatically for use in 3D machine vision.

Product	Throw ratio (WD/FoV)	Working distance (mm)	Base length (stereo base) (mm)	Configuration	LED Color Option	Software Option
STVL-DLS-1 Module	1.8	1300-3000	410	1 x DLP7000, 1 x Sony IMX174	standard: white 460 nm blue	P/N 9623 zSnapper® SDK software

					730 nm NIR 850 nm NIR	
STVL-DLS-2 Module	1.8	600 or 1000	160	1 x DLP7000, 2 x Sony IMX174	standard: white 460 nm blue 730 nm NIR 850 nm NIR	P/N 9623 zSnapper® SDK software
STVL-DLS-2 Industrial Module	1.8	600 or 1000	160	1 x DLP7000, 2 x Sony IMX174	standard: white 460 nm blue 730 nm NIR 850 nm NIR	P/N 9623 zSnapper® SDK software

3D imaging scanning system products

One of the application of our 3D scanning system is used in the areas of compression garments, whole-body measurement, prosthetics, orthopedic technology and posture analysis. This system offers the user a user-friendly user interface and is characterized by its ease of use. The system is not tied to a specific location, can be stowed away in a space-saving manner and is immediately ready for use after assembly.

<p>(A)</p> 	<p>3D Body Measurement consists of 3D scanning system which is a solution optimized for use in medical supply stores to supply customers with compression products. The scanning system consists of a mobile equipment trolley and the plugin.</p>
<p>(B)</p> 	<p>The Link is a mobile extension to the 3D scanning system which enables location-independent, mobile data acquisition of skin and tensile dimensions for the supply of circular and flat knitted products. Customer data and manual measurements are recorded in the tablet and transferred back to the store directly into the instrument's software. The entire range of the system is available for fast, digital processing of the ordering process.</p>
<p>(C)</p> 	<p>Compact 3D Scanning System is specially adapted to the needs of pharmacies, both in terms of space requirements and the range of functions of the software. The reduced working distance allows the 3D scanning system to be used in a smaller rooms. If the device is not needed, it can be stowed away quickly and in a space-saving manner.</p>
<p>(D)</p> 	<p>With Light Scanning System, we want to give our customers the opportunity to use the advantages of the scanning's software in the supply of compression stockings immediately after a product demonstration. With the transfer of the manually determined dimensions, all subsequent steps from product configuration to the transfer of the dimensions in online shops or to the ERP software are available to the user in the software. This product can be purchased as a stand-alone product if the premisses in the medical supply store do not offer enough space for the 3D scanning system.</p>

Please contact us for more information.