

Measurement of Laser Beam Profile and Propagation Characteristics

1. Laser Beam Measurement Capabilities

Laser beam profiling plays an important role in such applications as laser welding, laser focusing, and laser free-space communications. In these applications, laser profiling enables to capture the data needed to evaluate the change in the beam width and determine the details of the instantaneous beam shape, allowing manufacturers to evaluate the position of hot spots in the center of the beam and the changes in the beam's shape.

Digital wavefront cameras (DWC) with software can be used for measuring laser beam propagation parameters and wavefronts in pulsed and continuous modes, for lasers operating at visible to far-infrared wavelengths:

- beam propagation ratio M^2 ;
- width of the laser beam at waist w_0 ;
- laser beam divergence angle θ_x, θ_y ;
- waist location $z-z_0$;
- Rayleigh range Z_{Rx}, Z_{Ry} ;
- Ellipticity;
- PSF;
- Wavefront;
- Zernike aberration modes.

These parameters allow:

- controlling power density of your laser;
- controlling beam size, shape, uniformity, focus point and divergence;
- aligning delivery optics;
- aligning laser devices to lenses;
- tuning laser amplifiers.

Accurate knowledge of these parameters can strongly affect the laser performance for your application, as they highlight problems in laser beams and what corrections need to be taken to get it right.

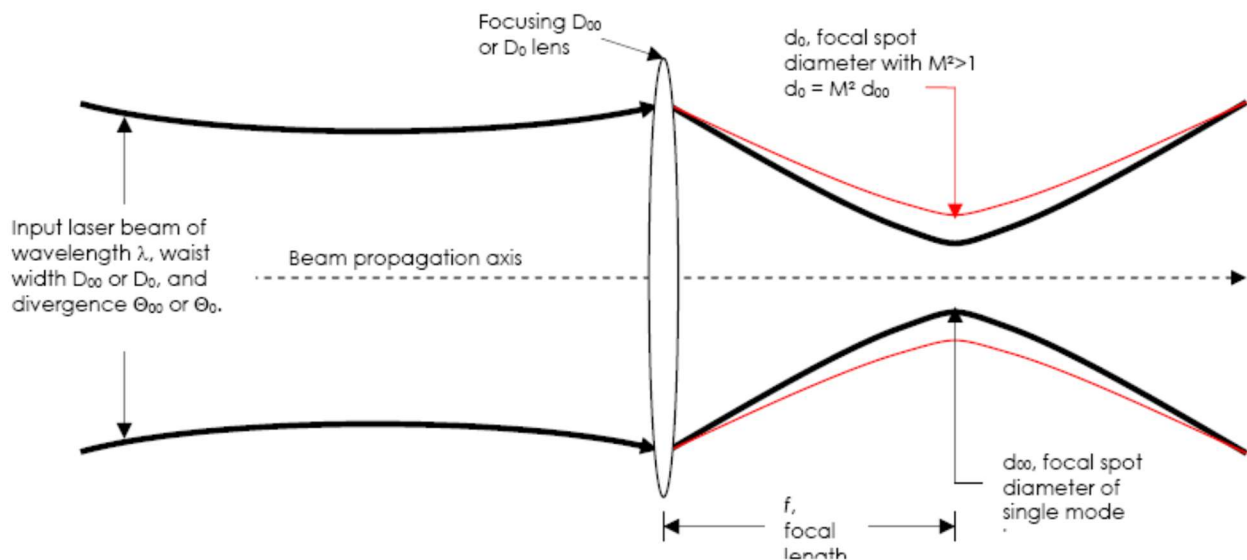

Figure 1. Characteristics of a laser beam as it passes through a focusing lens.

2. Beam Propagation Parameters

M^2 , or Beam Propagation Ratio, is a value that indicates how close a laser beam is to being a single mode TEM₀₀ beam. This in turn relates to how small a spot a laser can be focused. For a laser beam propagating through space, the equation for the divergence, Θ , of a pure Gaussian TEM₀₀ unfocused beam is given by:

$$\Theta_{00} = 4 \lambda / \pi D_{00} \quad (1)$$

where D_{00} is the waist diameter of the beam, and λ is the wavelength. Actual beams with additional modes often start with a larger beam waist, D_0 , and/or have a faster divergence Θ_0 . In this case Equation (1) becomes:

$$\Theta_0 = M^2 4 \lambda / \pi D_0 \quad (2)$$

where Θ_0 and D_0 are the divergence and width of a higher mode beam and M^2 is greater than 1 and is named the “Beam Propagation Ratio” per the ISO 11146 standard. When a pure Gaussian laser beam is focused, the diameter of the focused spot is defined by:

$$d_{00} = 4 \lambda f / \pi D_{00} \quad (3)$$

where D_{00} is the ideal focused spot diameter, f is the focal length of the lens, and is placed one focal length from the lens as shown in the Figure 1. However, when a distorted or multimode beam is focused, Equation (3) becomes:

$$d_0 = M^2 4 \lambda f / \pi D_0 \quad (4)$$

Apart from M^2 , the measured beam propagation parameters characterizing laser beams are:

$w_0 = d_0/2$ – the waist radius in X (horizontal) and Y (vertical) directions;

$z-z_0$ – the distance between measurement and waist planes;

z_R – the Rayleigh range, for which the radius of curvature R of the wavefront is minimal;

θ – the divergence angle of the measured laser beam far from the waist;

R – the radius of curvature of the wavefront in the measurement plane.

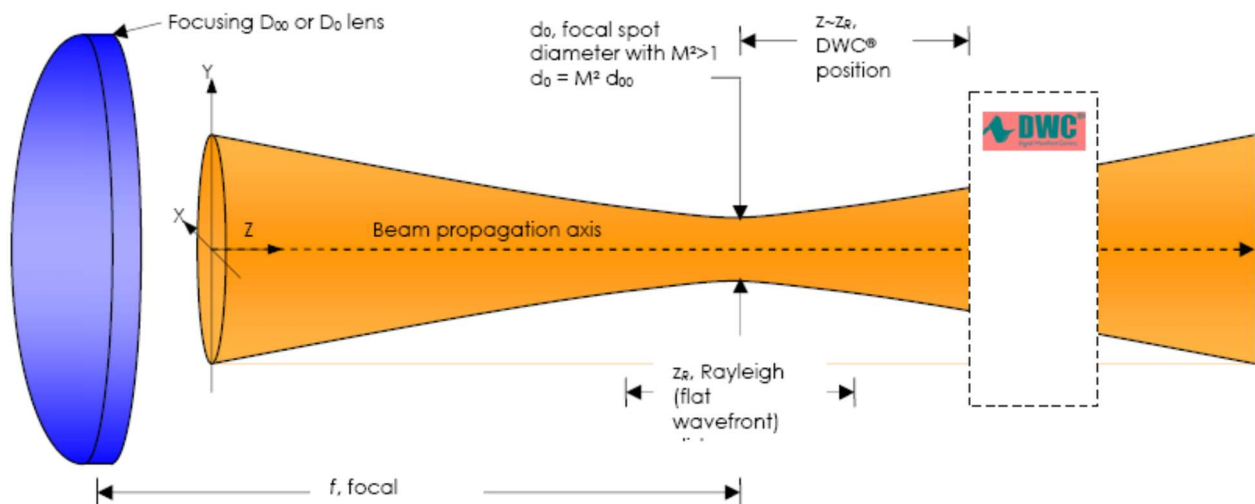

3. Measurement of Propagation Parameters with DWC

3.1 Principle

Propagation parameters are measured by DWC on real beams by focusing the beam with a fixed position lens of known focal length, and then measuring the characteristics of the artificially created beam waist and divergence.

Measurement of the beam propagation parameters with DWC is based on the simultaneous measurement of the high-resolution images of intensity and wavefront. The wavefront is computed starting from two slightly defocused beam intensity images acquired on one CCD camera inside DWC by mathematical computations involving the two images and the difference between them (Figure 2). From the wavefront, the beam propagation parameters are obtained by straightforward but tedious computations.

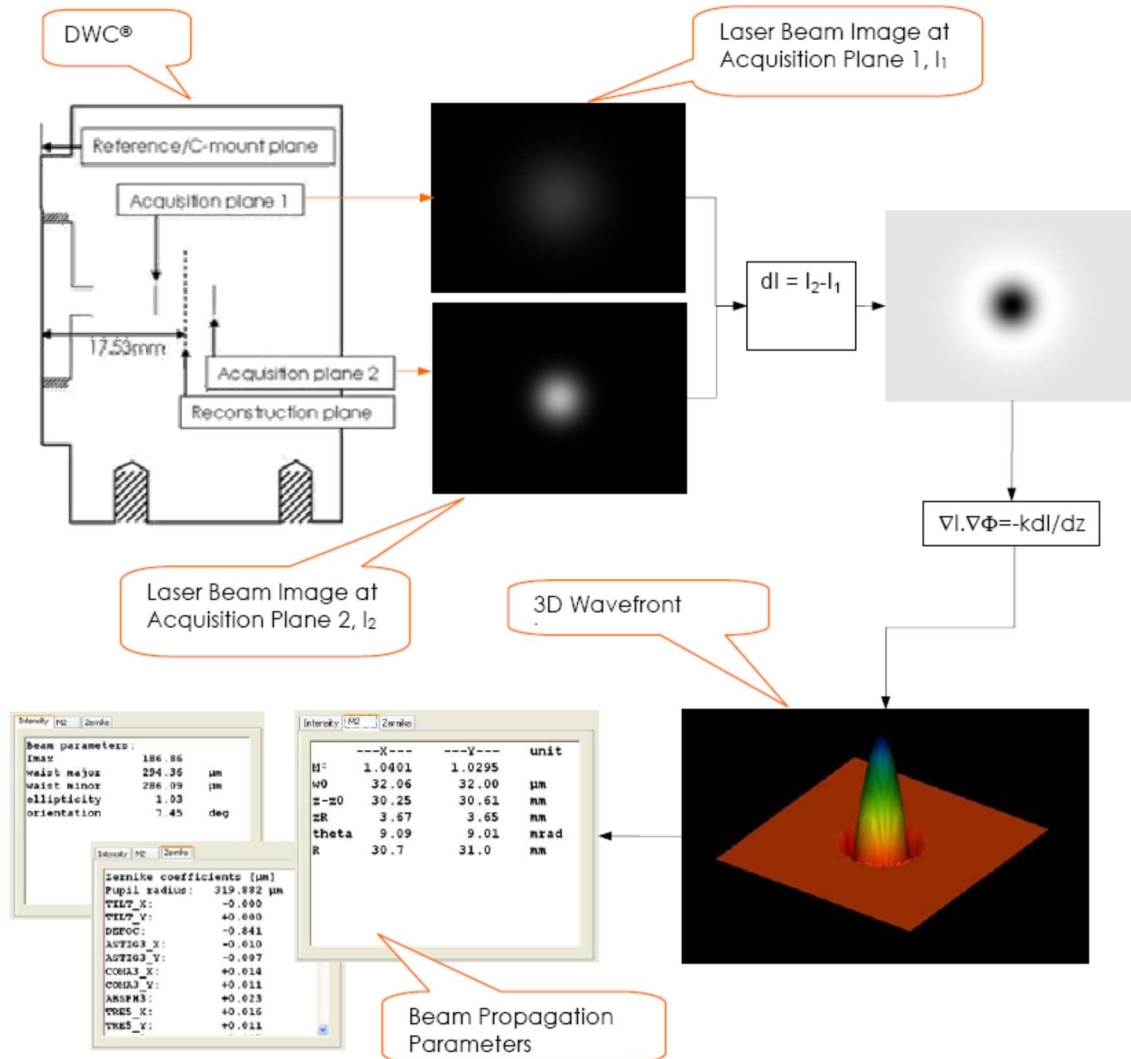

Figure 2. Principle of DWC: Acquisition of two images in real time at two different focal planes, wavefront extraction and computation of beam propagation parameters.

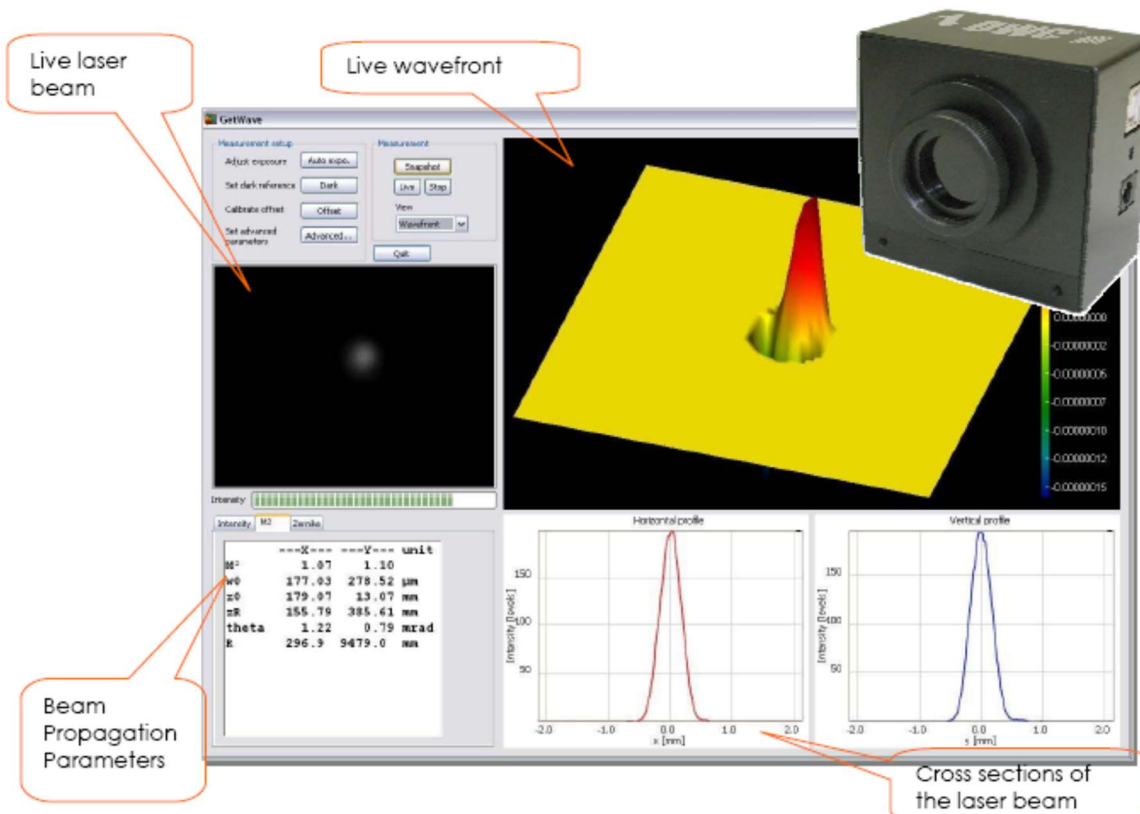

Figure 3. DWC and the Graphic User Interface of its associated software.

3.2 System Set-up

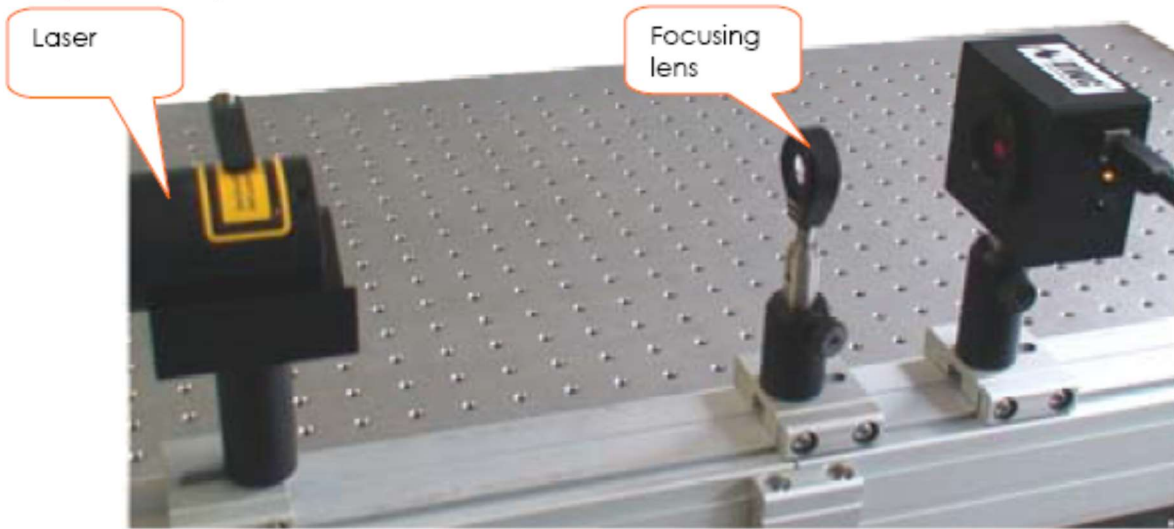
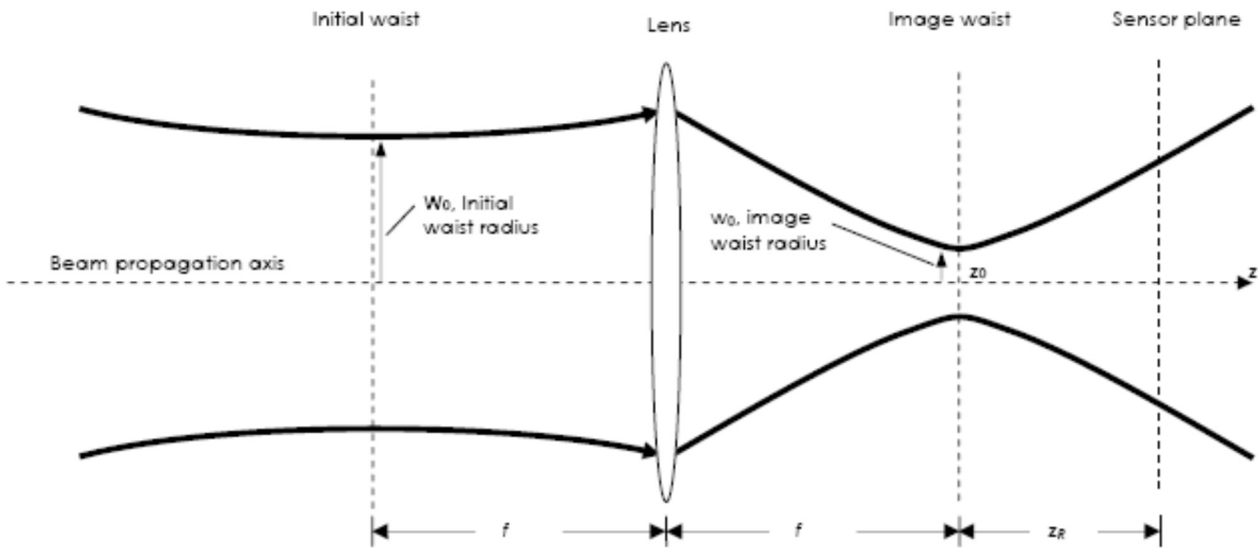

Figure 4. Example of a setup for measurement of laser propagation parameters with DWC.



VIS/NIR Beam Profiler: STCam CCD

Our CCD is developed to provide excellent sensitivity from the VIS to NIR spectral range. Thanks to its high resolution and its small pixel size, the STCam is a high performance tool for laser beam analysis of continuous wave (CW) and pulsed laser modes. Due to its high dynamic range the STCam captures even higher laser modes with outstanding detail.

The passive cooled sensor of the STCam is constructed without cover glass to avoid interference patterns. For sensor protection a low distortion neutral density filter is integrated. The STCam supports the ultra-fast FireWire IEEE 1394b interface with data transfer rates up to 800 Mbit/s. The plug and play design facilitates easy and flexible integration and operation.

The portable STCam is designed to be used in a variety of applications in industry, science, research and development, including:

- Laser beam analysis of CW and pulsed lasers,
- Quick control of laser modes and adjustment errors,
- Test equipment for scientific research,
- Near-Field and Far-Field analyses of lasers, LED devices and other light sources.

The enhancement of product quality, process reliability and efficiency are just a few of the many benefits of our unique beam profiler cameras. The STCam includes the specifically designed analysis software, STRayCi, which supports Windows XP/Vista operating systems. Its sophisticated software architecture opens up new opportunities in laser beam analysis according to ISO standards.

The concept of the STCam enables easy adaption to standard optical imaging systems, attenuators and opto-mechanical components ensuring highest flexibility. This includes:

- Microscope lens and beam expander,
- UV-Converter and IR-Converter,
- Fixed and variable attenuators, etc.

ACCESSORIES

Neutral Density Filter: To expand the power range of the STCam several absorptive and metallic-coated neutral density filters are available, which are specified by optical densities ranging from OD 1.0 to OD 4.0.

FireWire Component: We offer different FireWire PCI / PCI Express cards for installation direct into the PC. Standard FireWire cables are suitable for industrial applications and are available in various lengths.

Trigger Device: To synchronize the STCam with pulsed laser systems, our trigger device is perfectly suited. This frequency and delay generator is software controllable and enables the synchronization of up to four beam profilers with different delay times simultaneously.



	CCD-1201	CCD-2301	CCD-2302
SENSOR DATA			
Format	1/2"	2/3"	2/3"
Active area	6.5x4.8mm	9.0x6.7mm	8.5x7.1mm
Number of pixel	1388x1038 (1.4MPixel)	1388x1038 (1.4MPixel)	2452x2056 (5MPixel)
Pixel size	4.65x4.65µm	6.45x6.45µm	3.45x3.45µm
Spectral response without cover glass	350-1100nm	350-1100nm	350-1100nm
Laser beam diameter min/max	46.5/4mm	64.5µm/5mm	34.5µm/5.5mm
Sensor cooling	passive	passive	passive
CAMERA FEATURES			

Lens Mount	C-Mount	C-Mount	C-Mount
Bit depth (output)	14Bit	14Bit	14Bit
Dynamic (signal to noise)	60dB (1:1000)	67dB (1:2200)	54dB (1:500)
Frame rate	up to 15Hz	up to 16Hz	up to 9Hz
Exposure time	100µs-1s	100µs-1s	100µs-1s
Interface	FireWire (IEEE1394b)	FireWire (IEEE1394b)	FireWire (IEEE1394b)
I / O connector	12-Pin Hirose	12-Pin Hirose	12-Pin Hirose
Mode	CW or pulsed	CW or pulsed	CW or pulsed
Trigger	TTL-signal	TTL-signal	TTL-signal
Combinable with	IR-/UV-Converter Beam expander Attenuator	Beam expander Attenuator	Beam expander Attenuator
SPECIFICATIONS			
Mechanical dimensions (WxHxL)	60x60x103.8mm	60x60x103.8mm	60x60x103.8mm
Weight	300g	300g	300g
Electrical requirements	DC 8V-36V	DC 8V-36V	DC 8V-36V
Storage temperature*	-10°C...+60°C	-10°C...+60°C	-10°C...+60°C
Operating temperature*	+5°C...+45°C	+5°C...+45°C	+5°C...+45°C
Regulations	CE, RoHS	CE, RoHS	CE, RoHS

* without condensation

Neutral Density Filter

Our neutral density filters allow broadband attenuation for a spectral range from VIS to NIR. Due to their excellent surface quality the absorptive and reflective filters enable precise beam attenuation for low power applications. The level of attenuation is specified by the optical density. Filters with different optical densities can be combined. A filter adapter is available to mount the filters on the STCam aperture.



Reflective ND filter		Absorptive ND filter
NDR-10 / NDR-20 / NDR-30 / NDR-40		NDA-10 / NDA-20 / NDA-30 / NDA-40
Optical density*	1.0 / 2.0 / 3.0 / 4.0	1.0 / 2.0 / 3.0 / 4.0
Spectral range	200nm - 1200nm	400nm - 700nm / 700nm - 1200nm
Material	UV-Fused silica (Coating: Metal)	Schott glass
Flatness	1λ @ 300nm	λ/10 @ 632.8nm
Scratch-Dig	40 - 20	40 - 20
Parallelism:	3arcmin	10arcsec
Optical density tolerance	±5%	±5%
Power (Pmax)	< 1W	< 1W
Intensity (Imax)	0.75W/cm ²	1W/cm ²
Diameter	∅=25mm/25.4mm	∅=25mm/25.4mm
Operating temperature	< 100°C	< 100°C
Filter threads	Filter thread / Filter mount	Filter thread / Filter mount
Filter adapter	C-Mount thread / Filter thread	C-Mount thread / Filter thread

Laser Beam Profiling Software STRayCi

Our sophisticated beam profilers are available with the specifically designed analysis software, STRayCi, which supports Windows XP/Vista operating systems. It is available as 32 Bit / 64 Bit version and can control up to eight beam profiler cameras on a single computer.

Due to its clearly designed menu structure, STRayCi shows self-explanatory functions, which help the user to access quickly standard settings. Incomparable visualization modes, extensive analytical capabilities as well as new developed correction algorithms ensure the highest accuracy in laser beam analysis.

A wide range of beam width techniques e.g. 2nd Moment, Knife Edge, Moving Slit, Plateau, Gauss-Fit can be applied to determine quick and reliable standard beam parameters. The unique measurement tool enables the continuous monitoring of beam parameters, beam position and power density distribution. Helpful features like AOI Tracking, AOI Optimization, Zoom Functions, Look-Up Tables, etc. simplify the laser beam analysis.

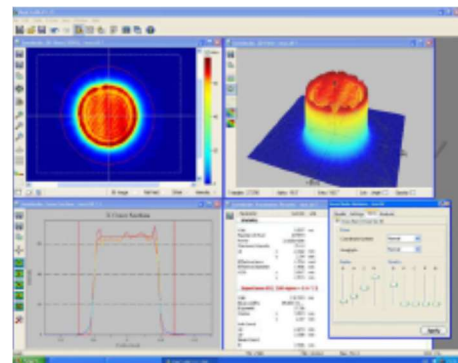

The extraordinary graphical and analytical tool of STRayCi can be used for live data (LiveMode) and stored data (SaveMode) simultaneously, while each mode has its own individual functions. This makes STRayCi the most advanced analysis software on the market.

STRayCi is equipped with flexible data and image output capabilities. This permits the user to store data and images in the format that is compatible with their needs.

A clearly arranged and printable protocol view displays the chosen measurement parameters as well as the most important laser beam analysis results.

STRayCi is compatible with guidelines of the international standard organization for laser beam measurements:

- ISO 11145: Vocabularies and symbols
- ISO 11146: Beam width, propagation ratio,...
- ISO 11670: Beam positional stability,...
- ISO 13694: Beam power density distribution,...

STRayCi works only with a USB software protection lock. It is a hardware based security solutions to protect and encrypt the software against piracy.

MINIMUM SYSTEM REQUIREMENTS:

- Windows XP / Vista
- Pentium IV / AMD Processor
- 128 MB graphic card, Open GL V1.4 compatible
- 100 MB free memory
- PCI / PCIe slot for FireWire card
- USB port for dongle connection
- CD / DVD-ROM drive for software installation
- Internet access for update request

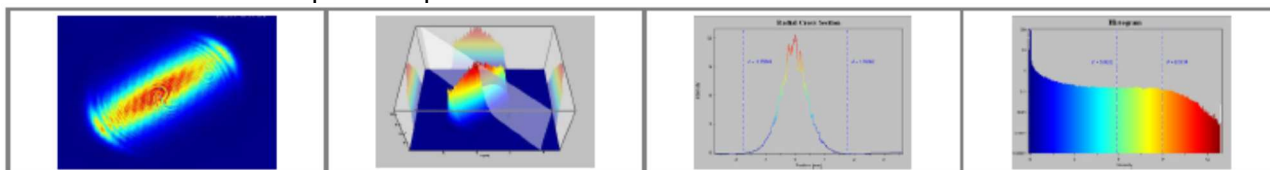

STRayCi Special Features

REAL-TIME BEAM PROFILING

2D / 3D intensity plots / Cross sections / Histogram

Pointing stability (x-y fluctuation, COG- position analysis, ect.)
 Parameter stability (intensity, power, center x-y, beam size)
 Parameter results (beam statistics, beam width, beam parameter)

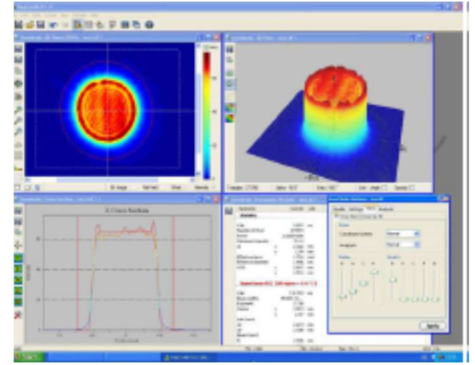

CAMERA CONTROL

Multiple camera support
 Different measure types
 User-selectable exposure time and gain factor, auto-exposure time
 Floating average and variable brightness

ANALYSIS FUNCTIONS

Beam statistics (power, max intensity, COG, etc.)
 Beam width (2nd Moment, Gauss / Super-Gauss-Fits, Plateau, Knife Edge, Moving Slit, ect.)
 Beam parameter (beam width, ellipticity, uniformity, etc.)

CALIBRATION AND CORRECTION TOOL

Background subtraction, auto-background
 Pixel correction technology (offset correction, linearity, etc.)
 Power calibration

OTHER FEATURES

User-defined Area of Interest (AOI)
 AOI tracking and optimization
 Color palettes incl. auto-contrast function
 Zoom functions
 2D profile arithmetic operations, filters, transformations, etc.
 E-mail support

FLEXIBLE OUTPUT

Data: txt, tiff
 Image: jpeg, png, bmp, gif, tiff
 Protocol: pdf

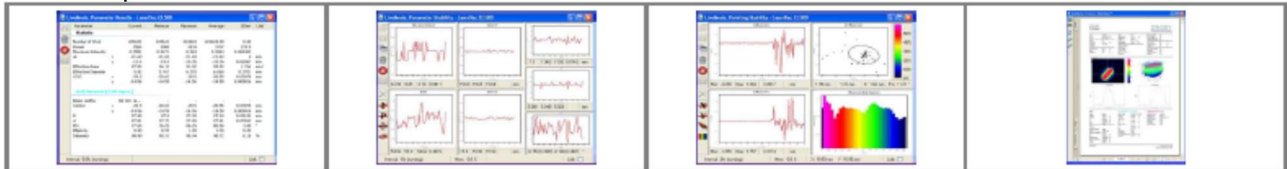

Beam Profiler: STCam CMOS

Most Cost-Effective Beam Profiler on the Market

The particular cost-effective beam profiler STCam CMOS is optimized to provide excellent sensitivity. The Megapixel CMOS sensor provides accurate laser beam analysis with up to 30fps. The lightweight and ultra-compact design enables easy adaption to standard optical imaging systems and opto-mechanical components ensuring highest flexibility.

- Small entry-level beam profiler
- High-resolution MPixel sensor without cover glass
- Real-time monitoring by high frame rate and dynamic range
- Standard high-speed USB 2.0 / 3.0 interface
- Different software versions available: Lite, Standard, Professional



Type	CMOS-1201 (1/2")	CMOS-1202 (1/1.8")	CMOS-1203 (1/1.8")	CMOS-1204 (1/2.5")
Spectral response:	400-1150nm	400-1320nm	400-1320nm	400-1150nm
Number of Pixel:	1.3MPixel	1.3MPixel	2MPixel	5MPixel
Pixel size:	5.2x5.2 μm^2	5.3x5.3 μm^2	4.5x4.5 μm^2	2.2x2.2 μm^2
Bit depth (Output):	8Bit	8Bit	8Bit	8Bit
Dynamic:	68dB	62dB	62dB	70dB
Dimensions:	40x40x20mm ³	40x40x20mm ³	40x40x20mm ³	40x40x20mm ³

Type	CMOS-1201- Nano (1/1.8")	CMOS-1.001- Nano (1")	CMOS-1201-Pico (1/2.5")
Spectral response:	400-1320nm	400-1320nm	400-1150nm
Number of Pixel:	1.3MPixel	4.2MPixel	5MPixel
Pixel size:	5.3x5.3 μm^2	5.5x5.5 μm^2	2.2x2.2 μm^2
Bit depth (Output):	10Bit	10Bit	12Bit
Dynamic:	62dB	60dB	70dB
Dimensions:	29x29x20mm ³	29x29x24mm ³	15x15x11.5mm ³

Remark: RT Option: 320-1150nm / UV Option: <150-1150nm or 240-1150nm / IR Option: 1470-1605nm

SDR series Beam Profiler

SDR-WCD-LCM 1" CMOS Beam Profiling Camera, USB3.0

With an 11.3 x 11.3 mm active area, 4.2 Mpixels, 5.5 x 5.5 μm pixels, optical and electronic triggering of a global shutter, and an update rate to 60+ Hz, the SDR-WCD-LCM series is ideally suited to both CW and pulsed laser beam profiling. The high resolution CMOS detector means no comet tailing, and the shutter and trigger options simplify pulse capture.

The SDR-WCD-LCM is paired with a full-featured software which has no license fees, unlimited installations, and free software updates. It is ideal for applications including: CW and pulse laser profiling; field servicing of laser systems; optical assembly; instrument alignment; beam wander and logging; R&D; OEM integration; quality control; and M^2 measurement with available M2DU stages.

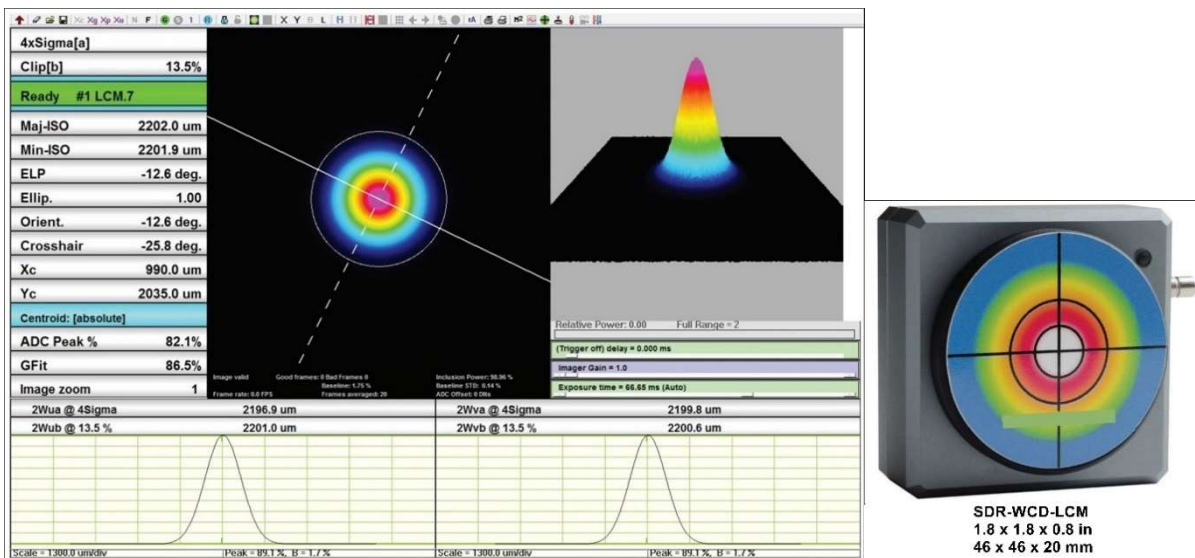

SDR-WCD-LCM
1.8 x 1.8 x 0.8 in
46 x 46 x 20 mm

System Features:

- 355 – 1150 nm (CMOS)
 - ✓ TEL sensor options for 1480-1610 nm
 - ✓ UV and 1310 nm options available
- 4.2 MPixel, 2048 x 2048 pixels, 11.3 x 11.3 mm active area
- 5.5 μm pixels
- 60 fps @ 512 x 512, 30 fps @ 1024 x 1024, 12 fps @ 2048 x 2048
- Port-powered USB 3.0
- HyperCal™ – Dynamic Noise and Baseline Correction software.
- MagND™ stackable magnetic ND filters or C-mount filters
- 2500:1 signal to RMS Noise
- Global shutter with TTL trigger
- Electronic auto-shutter, 85 μs to 2 sec (44dB)
- 12-bit ADC
- Isolated pulse triggering
- Parallel capture on multiple cameras
- Field-replaceable image sensors
- Relative power level display
- Window-free sensor standard for no fringing
- ISO 11146 M^2 option – beam propagation analysis, divergence, focus
- Available in specialized beam profiler systems
 - ✓ Industrial Laser Monitoring System (ILMS)
 - ✓ Large Beam Profiling system (LBPS)
 - ✓ Line Laser Profiling System (LLPS)

Applications:

- CW & pulsed laser profiling
- Field servicing of lasers and laser-based systems
- Optical assembly & instrument alignment
- Beam wander & logging
- M² measurements

Additional software features:

- XY profiles and centroids
- Linear and logarithmic displays
- Gaussian and Top Hat least squares fits
- Ellipse Angle, Major, Minor, Mean Diameters
- ISO 11146 compliant
- Background capture and subtraction
- Image & Intensity Zoom
- Linear and area filters
- Image Averaging, 1 to continuous
- Proprietary HyperCal™ Dynamic Noise and Baseline Correction

Model Specifications:

Specification	Detail	Notes
wavelength range:	SDR-WCD-LCM-UV :190–1150 nm	Incl. MagND-UV filters: ND 1, 2, 4 and MagND filters: ND 1, 2, 4
	SDR-WCD-LCM : 355-1150 nm	Incl. MagND filters: ND 1, 2, 4
	SDR-WCD-LCM-1310 :355-1350 nm	Incl. MagND filters: ND, 1, 2, 4, 1290 nm longpass filter
	SDR-WCD-LCM-TEL :1480-1610 nm	Incl. MagND filters: ND 1, 2, 4, 1290nm longpass filter
Image area (mm)	11.3 x 11.3	
Sensor	1" CMOS	
Resolution	4.2 MPixel (2048 x 2048)	
Pixel dimensions (µm)	5.5 x 5.5	SDR-WCD-LCM-TEL: effective pixel size is 25 µm
Min. beam (10 pixels)	55 µm	SDR-WCD-LCM-TEL: 250µm
Shutter type	Global	
Frame rate @ 2048 x 2048	≥ 12 Hz	
Frame rate @ 1024 x 1024	≥ 30 Hz	
Frame rate @ 512 x 512	≥ 60 Hz	
Max. "every pulse" PRR	USB 3.0: 12.6 kHz USB 2.0: 6.3 kHz	
Beam Diameter Accuracy	±2% (when used as specified)	
Signal to RMS Noise	2500:1, 34/68 dB opt/elec.	
Electronic shutter	25000:1, 85µs to 2s USB3.0 12500:1, 158µs to 2s USB 2.0	
ADC	12-bit	
Interface	USB3.0	

Outline & Mounting:

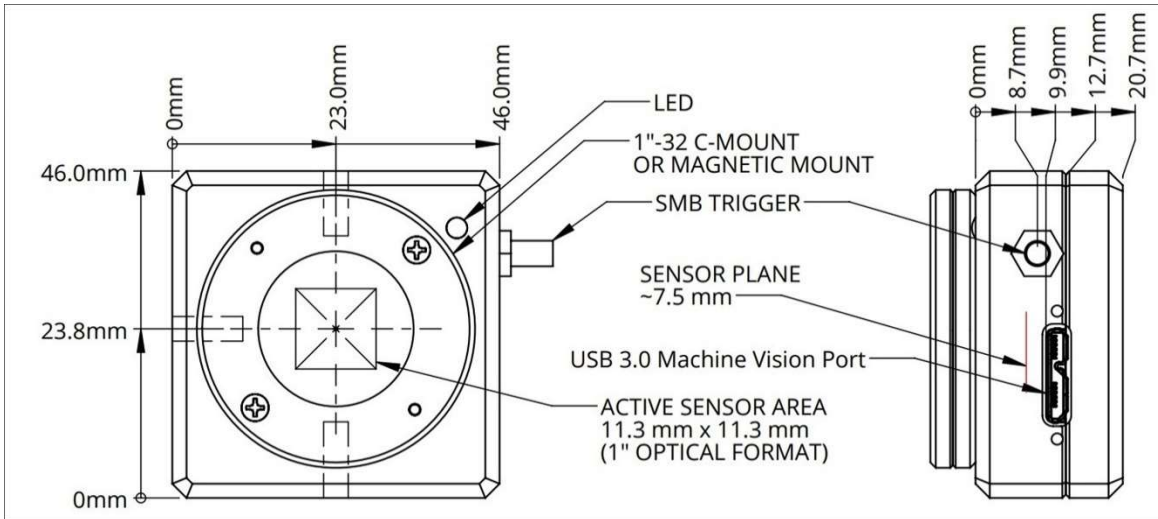

SDR-BC2

½" CMOS Beam Profiling Camera, Ultra Compact, USB3.0

With pixels as small as 3.2 μm , the high resolution and highly compact SDR-BC2 beam profilers have a thickness of only 0.50" (12.84mm) for insertion into tight optical trains and OEM applications.

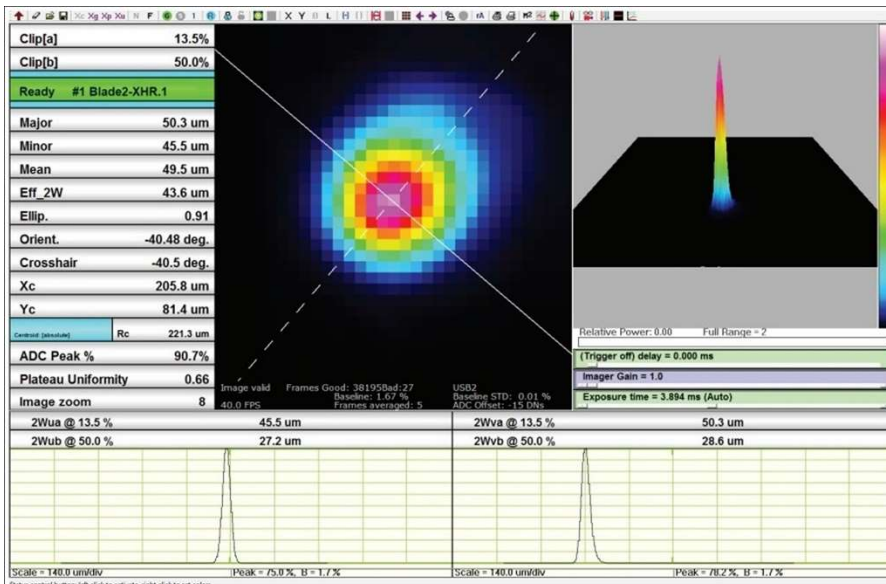

SDR-BC2
1.8 x 1.8 x 0.5 in
46 x 46 x 12.8 mm

System Features:

- 355 – 1150 nm, CMOS detector
 - ✓ TEL sensor options for 1480 – 1610 nm
 - ✓ UV and 1310 nm options available
- Two sensor pixel size/resolution options
 - ✓ SDR-BC2-XHR: 3.2 μm pixels, 3.1 MPixel, 2048 x 1536
 - ✓ SDR-BC2-HR: 5.2 μm pixels, 1.3 MPixel, 1280 x 1024
- 6 fps @ 2048 x 1526, 16 fps @ 1024 x 1024, 35 fps @ 512 x 512
- Port-powered USB 3.0
- HyperCal™ – Dynamic Noise and Baseline Correction
- C-mount filters included
- 1000:1 signal to RMS noise
- CW/Quasi-CW
- Electronic auto-shutter, 40 μs – 1s (XHR) or 40 μs – 500 ms(HR)
- 10-bit ADC
- Parallel capture on multiple cameras
- Field-replaceable image sensors
- Relative power level display

- Window-free sensors standard for no fringing
- ISO 11146 M² option – beam propagation analysis, divergence, focus

Applications:

- CW/Quasi-CW
- Field servicing of lasers and laser-based systems
- Optical assembly and instrument alignment
- Beam wander and logging
- M² measurements
- Small form factor for tight optical trains

Model Specifications:

SDR-BC2™	SDR-BC2-XHR	SDR-BC2-HR	SDR-BC2-HR-TEL
Pixel count	3.2 MPixel	1.3 MPixel	
H x V	2048 x 1536	1280 x 1024	
Sensor image area (mm)	6.5 x 4.9	6.6 x 5.3	
Pixel dimension (µm)	3.2 x 3.2	5.2 x 5.2	25 (due to phosphor)
Min. beam (10 pixels)	32 µm	52 µm	250 µm
wavelength range	355 – 1100 nm		1480 – 1680 nm
Shutter type	Rolling		
Max frame rate:	> 6Hz	N/A	
Frame rate @ 2048 x 1536			
Frame rate @ 1024 x 1024	>16 Hz		
Frame rate @ 512 x 512	>35 Hz		
Max. 'every pulse' PRR	Not suitable for pulse capture		
Single pulse capture PRR	Not suitable for pulse capture		
Signal to RMS Noise (Optical/Electrical)	1000:1 (30/60 dB)		
Electronic shutter dynamic range	40 µs to 1 s 44dB	40 µs to 500ms 41 dB	
ADC	10-bit		
Interface	USB 3.0/2.0		

Outline and Mounting:

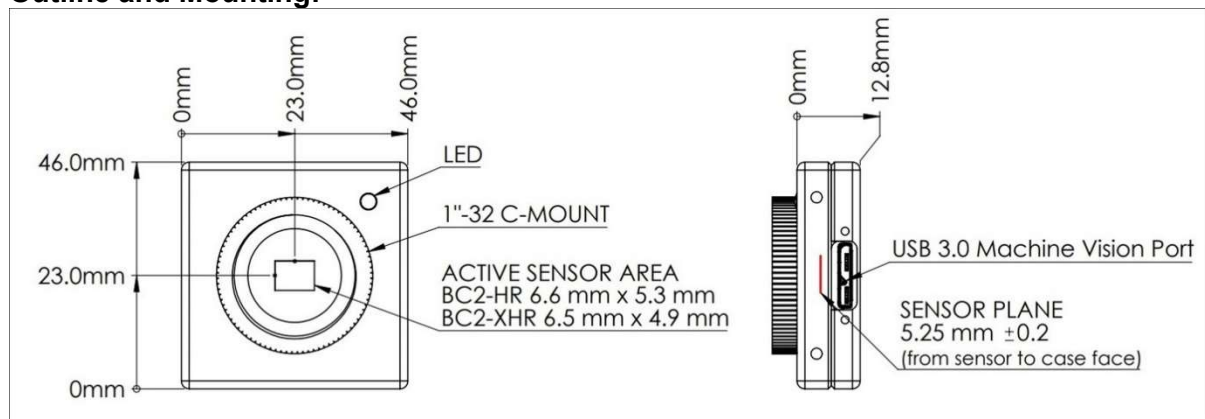

SDR-TCD-LCM Large Area CMOS Beam Profiler



BeamMap2
2.4 x 2.3 x 2.62"

Our SDR-Beam'R2 is well suited for many laser beam profiling applications. With both standard 2.5µm slits and larger knife-edge slits, the SDR-Beam'R2 is capable of measuring beams with diameters as small as 2µm. With options for both silicon and InGaAs or extended InGaAs, the SDR-Beam'R2 can profile beams from 190 nm to 2500 nm. Scanning slit instruments offer much higher resolution than camera-based systems.

Our SDR-BeamMap2 represents a radically different approach to real-time beam profiling. It extends the SDR-Beam'R2's measurement capabilities by allowing for measurements at multiple locations along the beam's travel. This real-time slit scanning system uses XY slit pairs in multiple z planes on a rotating puck to simultaneously measure four beam profiles at four different z locations. The SDR-BeamMap2's unique, patented design is most advantageous for real-time measurement of focus position, M², beam divergence and pointing.

System Features:

- ISO compliant beam diameter measurements
- Port-powered USB2.0
- Auto-gain function
- Optional stage accessory for ISO 11146 compliant M2 measurements.
- True2D slits
- Resolution up to 0.1µm
- Detector options, 190 – 2500 nm
- 5 Hz update rate (user adjustable 2-12 Hz)
- Measure high repetition pulsed lasers
- Pulsed Minimum PRR = $[500 / (\text{beam diameter in } \mu\text{m})]$ kHz

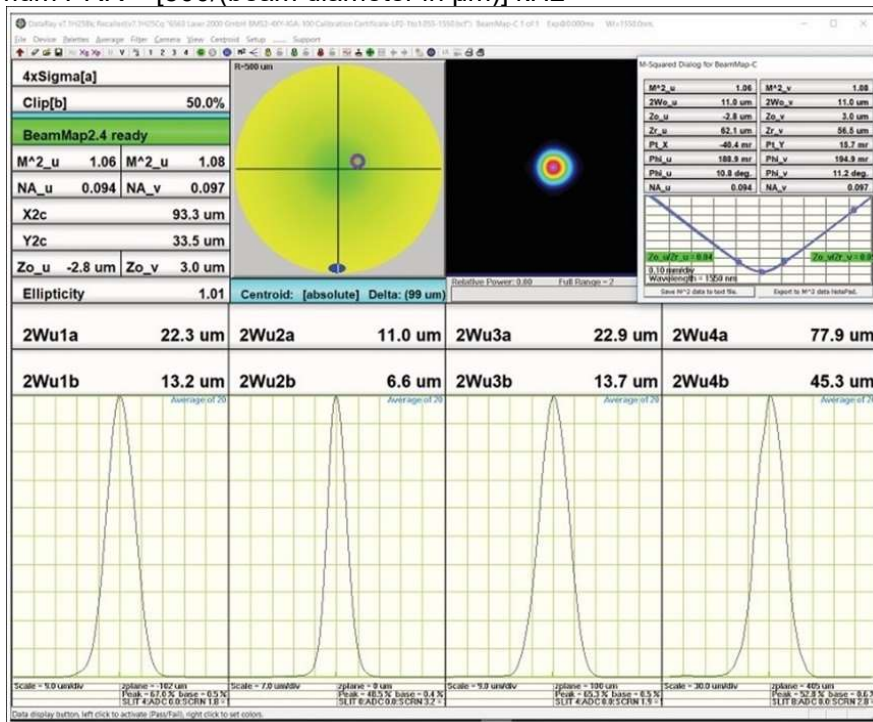

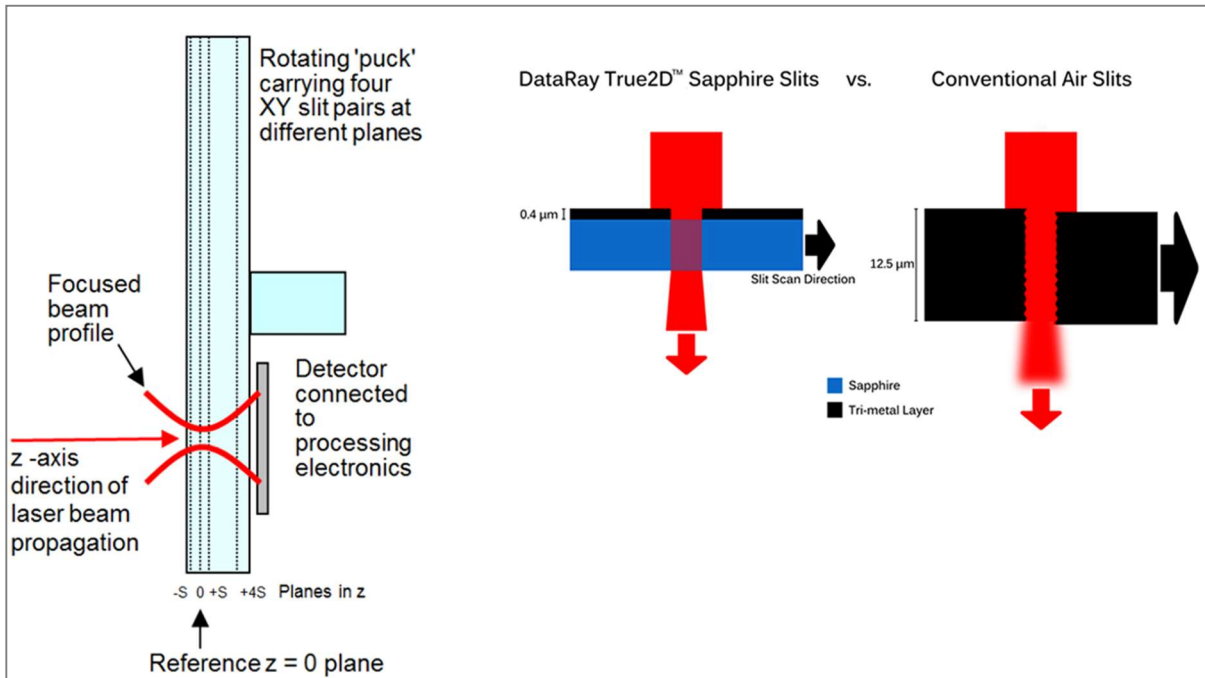

BeamMap2 adds the following features

- Multiple z-plane scanning
- XYZ profiles, plus θ - Φ
- Focus position and diameter
- Real-time M2, Pointing, and Divergence
- Measure divergence of well-collimated beam in real-time with BeamMap2-Collimate
- Identify focus with $\pm 1\mu\text{m}$ repeatability (beam dependent)
- Optional LensPlate2 for reaching inaccessible beam waists and reimaging waveguides

Applications

- Very small laser beam profiling
- Optical assembly and instrument alignment
- OEM integration
- Lens focal length testing
- Real-time diagnosis of focusing and alignment errors
- Real-time setting of multiple assemblies to the same focus

True2D Slits

- 0.4 μm thick metallic multilayer films on a sapphire substrate
- Advantages over air slits
- Avoid tunnel effect
- Air slits are typically deeper than they are wide, and can buckle under high irradiance

Specifications				
Parameter	Specification	SDR-BeamMap2	SDR-Beam'R2	Comments
Wavelength options:	190-1150 nm, 650-1800 nm, 190-1800 nm, 190-2500 nm	Yes	Yes	Si, InGaAs, Si + InGaAs, Si + InGaAs, extended
Scanned beam diameters:	2 μm to 4 mm (2 mm for IGA-X.X)	Yes	Yes	
X-Y Profile & Centroid Resolution: Accuracy:	0.1 μm or 0.05% of scan range $\pm <2\% \pm \leq 0.5\mu\text{m}$	Yes	Yes	
CW or Pulsed	CW, Pulsed Minimum PRR $\approx [500/(\text{Beam diameter in } \mu\text{m})]\text{kHz}$	Yes	Yes	

Beam alignment:	± 1 mrad with BeamMap2 ColliMate	Yes	-	Beam Dependent
M2 measurement:	1 to >20, ± 5%	Yes	-	4 Z-plane hyperbolic fit
Real-time update:	5 Hz	Yes	Yes	Adjustable 2-12 Hz
Maximum Power & Irradiance:	1 W Total & 0.3 mW/μm ²	Yes	Yes	Metallic film on Sapphire slits
Gain Range:	32dB	Yes	Yes	12-bit ADC
Display graphics:	All: X-Y position; Profiles. BeamMap2 only: M2, Focus; Divergence, Boresight/Pointing			

SDR-CAMIR Adapter

A cost-effective Telecom C-band* NIR image converter

- Extends the range of our standard silicon cameras into the near-infrared 1480 to 1605nm
- No image fading or lag time
- Cost effective for beams ≥ 500μm
- High quality AR coated optics

Applications: The CamIR Adapter* extends silicon camera sensitivity into the near IR range 1480-1605 nm, the telecom C, L & S* bands. This C-Mount module attaches to our standard cameras.

Technology: A proprietary phosphor converts 1480-1605 nm photons to Silicon CMOS/ CCD detectable wavelengths image to the attached CMOS/CCD camera at a demagnification of x0.29 (PMF=3.5) to give an effective active area of 22 x 16.5 mm with a 1/2", 1/1.8", 2/3", or 1" cameras.



The effective pixel size is 3.5 x the actual pixel size, but due to the phosphor, the primary limitation is the phosphors point spread function of ~70μm FWHM, and ~200μm at 1/e².

The response to incoming irradiance is logarithmic. This is automatically corrected in our software, by setting the Gamma in Setup to 1.41. Like any phosphor, the response is spatially non-uniform. Typical beam diameter measurement accuracy is around 5 to 10%.

Performance and Pricing: This technology is better than the low resolution and image lag of IR vidicons, yet less sensitive and less uniform than InGaAs arrays.

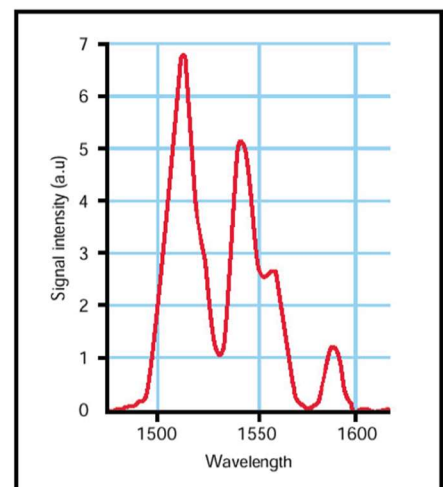
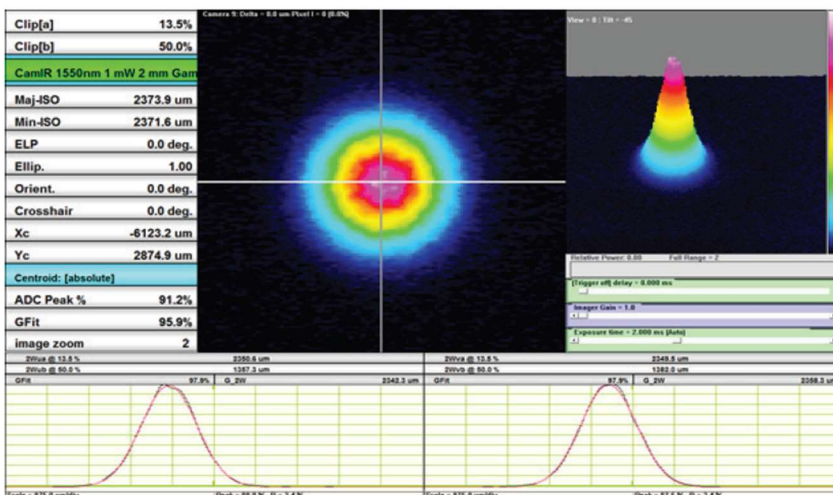

*S-band: 1460 - 1530, C-band: 1530 - 1565, L-band: 1565 - 1625

Technical Specifications:	
Optical Characteristics	
Active Area	27.5 mm
IR Spectral Sensitivity	1480 - 1605 nm (see curve)
Peak IR Sensitivity	1510/1540 nm (see curve)
Maximum Resolution	12lp/mm over active area
Converter IR Output	950 - 1075nm
Distortion	-1.0% Barrel Distortion (Inverted Image)
Linearity	Non-Linear IR converter output ~ (IR input intensity) ^{1.41}
Maximum Illumination	1W/cm ² (damage may occur if this limit is exceeded)
Other Characteristics	
Dimensions	Φ 46 mm x L 97 mm
Operating Temperature	-10° C to +40° C
Weight	210g
Requirements	
Mount	C-Mount (adapter supplied)
Effective Aperture	17 mm, 19 mm, 23 mm, 27.5 mm
Camera Format	1/2", 1/1.8", 2/3", 1" formats

Application Areas

- Beam intensity profiling of telecom diodes/devices
- Imaging optical outputs of components such as optical fiber ends, amplifiers, routers and switchers, fiber gratings, splitters and couplers
- On Line Production Alignment and Characterization –Real time Lens focusing
- Stability Testing- Beam Wander over time
- Divergence measurements
- Co-Linear Measurements Aligning two lasers
- Multiple Image separation Measurements (distance between peaks)
- Measure Relative Intensity

For researchers requiring higher resolutions. We offer the phosphor coating applied directly onto the sensor. This improves the point spread function to ~ 35µm FWHM.

This option is offered on the following cameras:

Model	Description
SDR-WCD-LCM1-NIR	1" CMOS USB 3.0/2.0 system with phosphor coating for 1480 to 1605nm.
SDR-WCD-UHR-NIR	1/2" CMOS system with phosphor coating for 1480 to 1605 nm.
SDR-BladeCam-UHR-NIR	1/2" CMOS system with phosphor coating for 1480 to 1605 nm.
SDR-WCD-UCD12-NIR	1/2" CCD system with phosphor coating for 1480 to 1605 nm.
SDR-WCD-UCD23-NIR	2/3" CCD system with phosphor coating for 1480 to 1605 nm.
SDR-TCD20-15-UCD23-NIR	20 x 15 mm CCD system with phosphor coating for 1480 to 1605 nm.

SDR-ILMS

Industrial Laser Monitoring System (ILMS)

The SDR-ILMS is designed for profiling focused, high-power industrial lasers. This system combines reimaging/magnification optics, a polarization preserving beam sampler, and a DataRay beam profiler to measure small beam waists which would otherwise damage a traditional profiling system. Magnification of the focused beam allows full pixel-by-pixel 2D measurements of beam spots as small as a few microns.

The SDR-ILMS is compatible with most DataRay profilers and supported by the full-featured, highly customizable, and user-centric software (included without licensing fees). The software automatically accounts for the magnification of the system, so results do not require post processing or corrections.

System Features:

- UV, visible, NIR, MWIR, SWIR, eSWIR and FIR options.
- High magnification options available (50X And beyond)
- High-power beams (handling up to kW)
- Three swappable filters for flexible, fine Attenuation
- Profiler easily removed from system for stand-alone use
- Optional calibrated pinhole apertures
- Integrated power meter and beam dumps available
- Profiling beam waist diameters down to a few μm .



Applications:

- Tightly focused beams, fiber ends, edge couplers, laser diodes and more.
- High power laser cutting systems
- Additive manufacturing
- Quality control

Application Examples – Additive and Subtractive Manufacturing

F-theta lenses are useful in additive and subtractive manufacturing for their ability to focus high-power beams over a range of XY locations at the focal plane. It is often useful to observe detailed 2D profiles of these focused beams.

Example: A 160-mm focal length F-theta lens focuses a 3.5-mm diameter collimated 343-nm laser to a minimum beam waist diameter of roughly $26 \mu\text{m}$. The pixel size of traditional profiling cameras makes it challenging to accurately profile a waist this small. However, since the SDR-ILMS-5-UV utilizes magnification optics, full 2D profiles of tightly focused beam are possible, allowing you to diagnose hard-to-find issues such as hot spots or unexpected beam ellipticity.

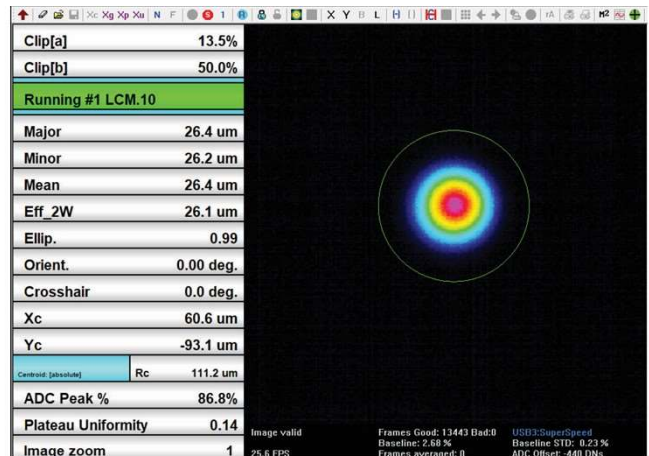

Application Examples – Inaccessible Beam Waists

In many applications a beam waist is not accessible for measurements. Examples include the output facet of VCSELS, the end of optical fibers, or short working distance focusing optics. The SDR-ILMS easily reimages inaccessible beam waists making it possible to tackle these difficult applications.

Example: We need to profile the end of a $7\text{-}\mu\text{m}$ core diameter, single mode fiber being used with a 1064-nm fiber-coupled source. The optics in our SDR-ILMS-50-1064 magnify the fiber end onto a SDR-WCD-LCM. It is challenging to position a traditional profiler close enough to the fiber for near-field profiling.

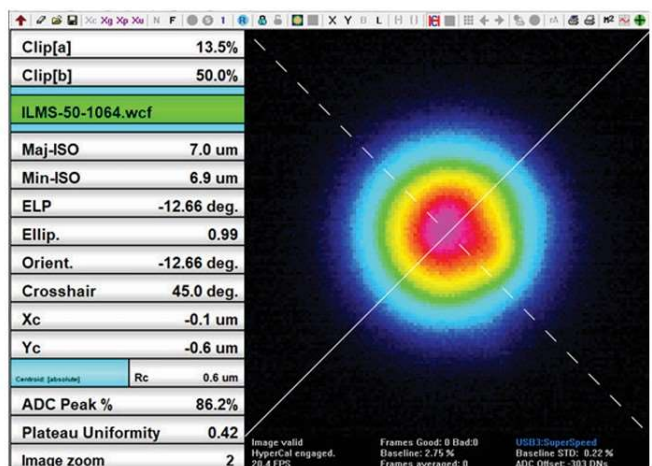

Standard Configurations:

Model	Magnification	AR coating wavelength (nm)	Input NA	System Dimensions (mm)	Typical spot size ($1/e^2$, μm)
SDR-ILMS-5-UV	5x	250-425	0.17	70.0 x 133.3 x 176.3	11
SDR-ILMS-5-VIS	5x	425-675	0.17		11
SDR-ILMS-5-NIR	5x	750-1550	0.17		11
SDR-ILMS-10-UV	10x	250-425	0.17	70.0 x 133.3 x 252.5	5.5
SDR-ILMS-10-VIS	10x	425-675	0.17		5.5
SDR-ILMS-10-NIR	10x	750-1550	0.17		9
SDR-ILMS-50-532	50x	495-570	0.6	70.0 x 133.3 x 328.7	2
SDR-ILMS-50-1064	50x	980-1130	0.65		3

Drawings:

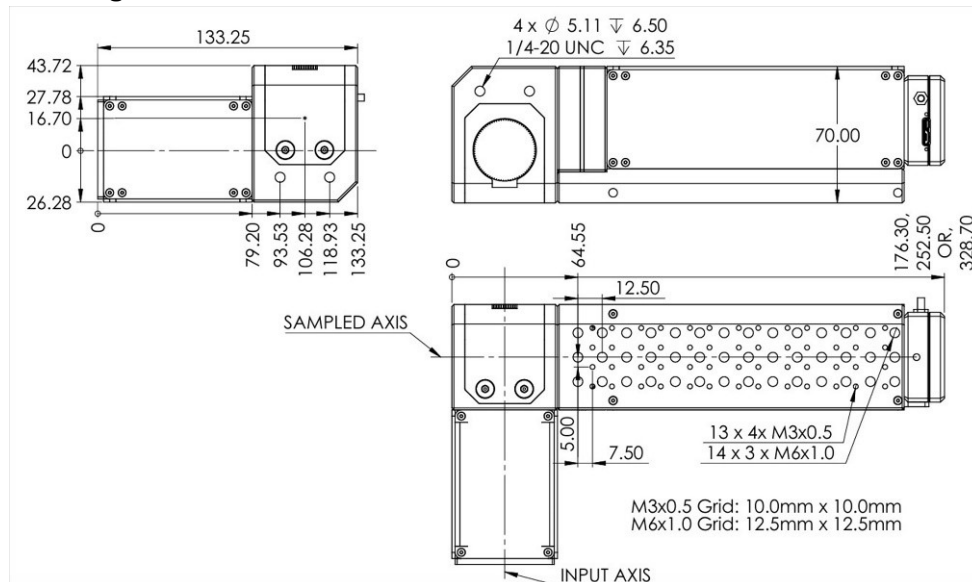

SDR-LLPS Line Laser Profiling System (LLPS)

The Line Laser Profiling System (LLPS) is a complete solution for analyzing line lasers up to 200mm in length and down to 55 μm in width. By scanning Flagship SDR-WCD-LCM beam profiling camera cross the length of the beam using 200mm linear stage, the full-featured, free software will display a full image of the line laser intensity distribution along with a vertical centroid plot, line width plot and several other useful measurements.

The line laser profiling system is supported by full-featured, highly customizable, user-centric software which has no license fees, unlimited installations, and free software updates. The software controls the movements of the stage, automatically configures the optimal exposure time for the line laser scan, and provides an analysis of the line.

Software features:

- Automatic exposure configuration
- Custom Start/End locations
- Automatic PDF report generation
- Residual sensor tilt compensation
- Export data to Excel or CSV
- Save/load line laser files (*.l_wcf)

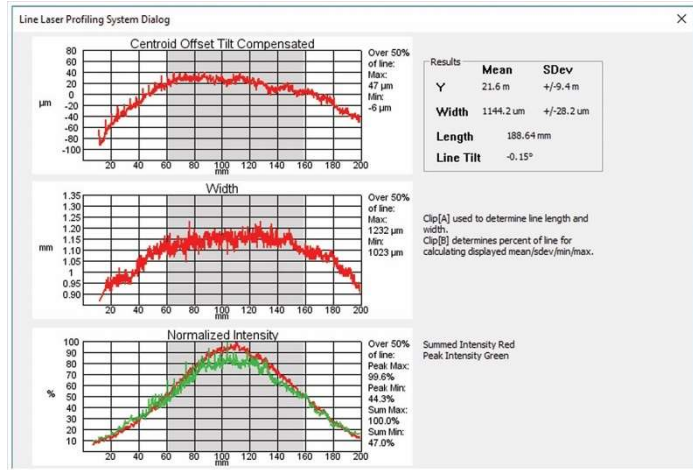

System Features:

Part number	SDR-LLPS-50	SDR-LLPS-200
Translation stage	50mm	200mm

- Line laser length/width measurements
- Absolute vertical centroids
- Deviation of vertical centroids from a linear regression line
- Line tilt measured in degrees
- 190 to 1150nm, CMOS detector
 - ✓ 4.2 MPixel, 2048 x 2048 pixels
 - ✓ 11.3 x 11.3 mm active area
 - ✓ 5.5 µm pixel size
- HyperCal™ – Dynamic Noise and Baseline Correction software
- 2500:1 signal to RMS noise
- 12-bit ADC
- Window-free sensors standard to prevent fringing



Applications:

- Calibration
- Machine Vision
- 3D scanning
- Particle counting
- Survey Instruments

STC Series Laser Beam Profilers

Our laser beam profiles can be used for monitoring focused and collimated spots of solid-state lasers, fiber lasers and diode lasers. It is widely used for research and industrial applications. The software interface displays 2D and 3D energy distributions and laser beam profile characteristics such as spot diameter, divergence angle and ellipticity.

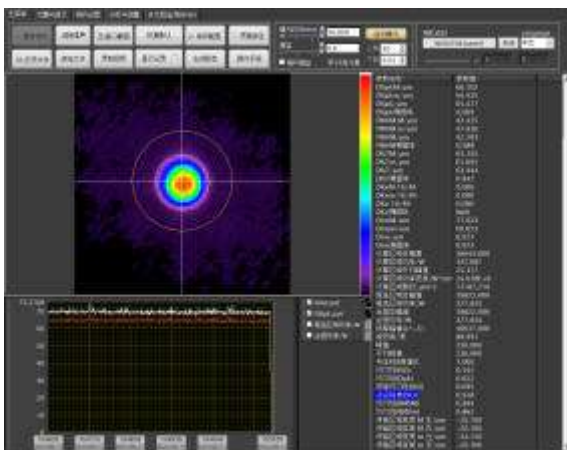
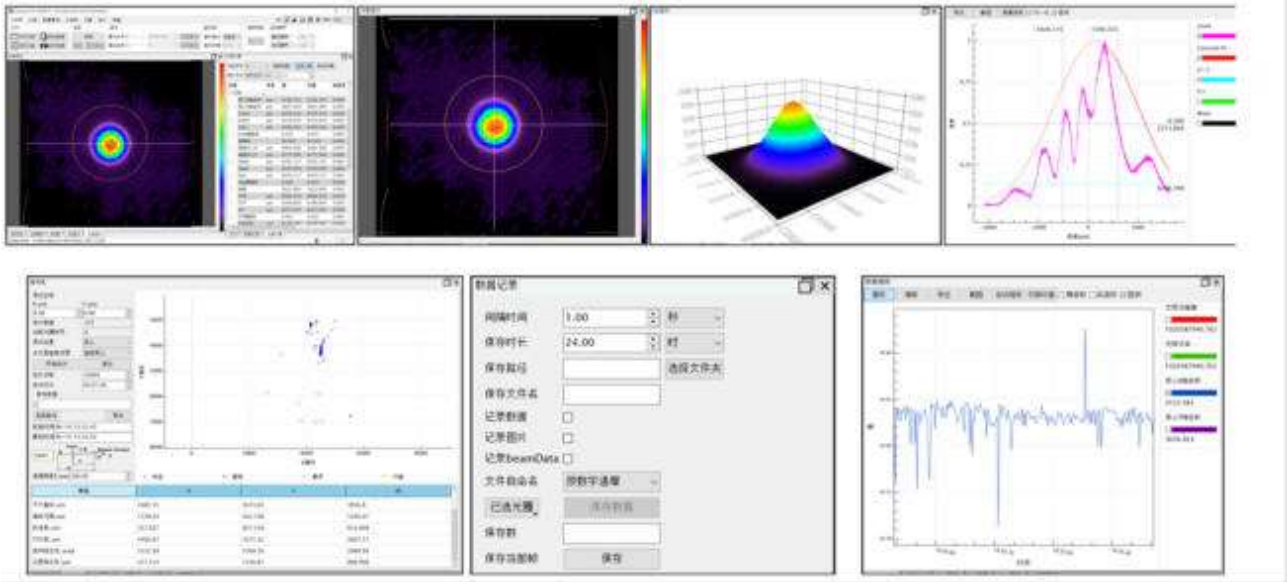

Spot Profile Analysis

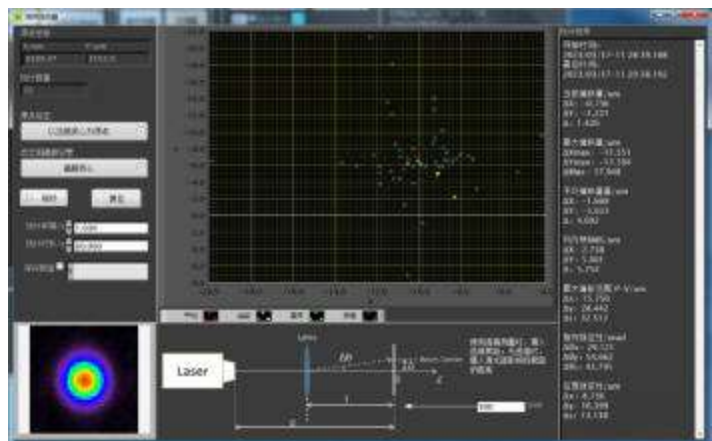

Pointing Stability Testing

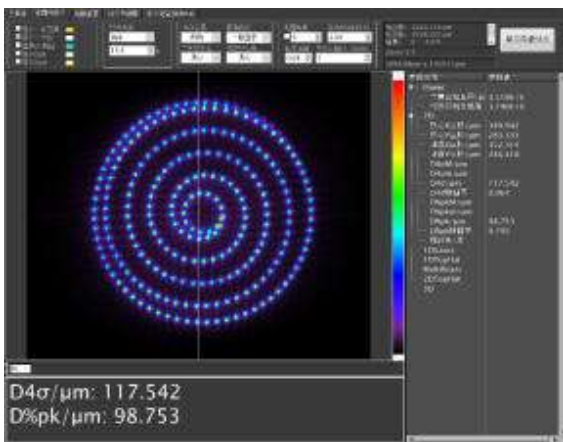

Galvanometer Scanning Accuracy

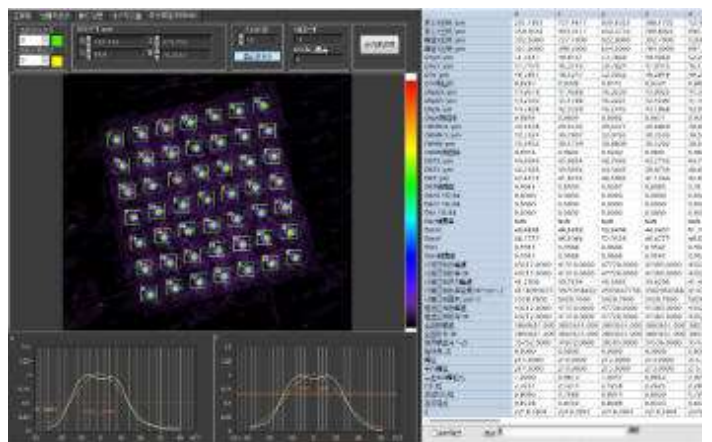

Multi-beam Detection

1. Compact Series



- Beam diameter range: 50um-3.6mm
- Output power up to 1W

Features:

- Spectral range: 190-1100nm
- Beam diameter: 35µm~7.1mm
- Maximum power to 50W
- PC software

Specifications:

Model number	STC307UV-M
Spectral range (nm)	190-1100/300~1100
Sensor size (mm)	8.4*7.1
Minimal beam size (µm)	35
Maximum beam size (mm)	7.1
Maximum acceptance angle	Collimated: ±2.5° Focused: NA0.08
Minimal power (mW)	1
Maximum power (W)	50
Detection time	2 minutes
Parfocal tolerance (mm)	0.05
Defocusing measurement Range	±5mm, calculated based on the parfocal distance of 95mm
Attenuator	OD0.0~4.5 (optional)
Communication interface	USB 3.0
External triggering	Available
Operating environment	Temperature <15~25°C; Relative humidity <60%
Operating environment	Temperature <0~35°C; Relative humidity <60%; Pointing test temperature: 15-25°C
Operating system	Windows 10/11; Optimum resolution: 1920*1080
Weight (kg)	<1

Features:

- Spectral range: 190-1100nm
- Beam diameter: 35µm~10.4mm
- Maximum power to 50W
- PC software

Specifications:

Model number	STC310UV-M
Spectral range (nm)	190-1100
Sensor size (mm)	14.1 * 10.4
Minimum beam diameter (µm)	35
Maximum beam diameter (mm)	10.4

Maximum acceptance angle	Collimated: $\pm 2.5^\circ$ Focused: NA0.08
Minimum power (mW)	1
Maximum power (W)	50
Detection time	2 minutes
Parfocal tolerance(mm)	0.05
Defocusing measurement range	± 5 mm, calculated based on the parfocal distance of 95mm
Attenuator	OD0.0~4.5 (optional)
Communication interface	USB 3.0
External triggering	Available
Operating environment	Temperature<0~35C; Relative humidity<60%; Pointing test temperature: 15-25C
Operating system	Windows 10/11; Optimum resolution: 1920*1080
Weight (kg)	<1

2. Medium Power Series



- Beam diameter range: 50um-6.5mm
- Output power up to 500W

Features:

- Spectral range: 1030- 1070nm
- Beam diameter: 50 μ m~ 7.1mm
- Maximum power to 500W
- PC software

Specifications:

Model number	STC307NIR-W
Spectral range (nm)	1030-1070
Sensor size (μ m)	3.45
Maximum sensor area (mm)	8.4*7.1
Minimal beam size (μ m)	50
Maximum beam size (mm)	7.1
Maximum acceptance angle	$\pm 2.5^\circ$ @ Center incidence ± 0.05 mm
Minimal power (W)	0.1 @50 μ m
Maximum power	500W, focused beam $\geq 100\mu$ m CW 300W, focused beam $\geq 50\mu$ m CW
Parfocal tolerance (mm)	± 0.5
Defocusing measurement range	-10mm~+5mm, calculated based on the parfocal distance of 96mm
Detection time	≤ 1 minute @500W, ≤ 3 minutes @300W, CW@200W
Attenuator	OD4.5~8 (optional)
Communication interface	USB 3.0
External triggering	Available

Cooled method	Air cooled, water cooled, flow 10L/min, water temperature 20~25°C, 0.5~1kW cooling capacity, pressure 10~25m
Operating environment	Temperature <0~35°C; Relative humidity <60%; Pointing test temperature: 15-25°C
Operating system	Windows 10/11; Optimum resolution: 1920×1080
Weight (kg)	<1.5

Features:

- Spectral range: 1030-1070nm
- Beam diameter: 50μm~10.4mm
- Maximum power to 500W
- PC software

Specifications:

Model number	STC310NIR-W
Spectral range (nm)	1030-1070
Sensor size (um)	3.45
Maximum sensor area (mm)	14.1*10.4
Minimal beam size (μm)	50
Maximum beam size (mm)	10.4
Maximum acceptance angle	±2.5°@ Center incidence ±0.05mm
Minimal power (W)	0.1 @50μm
Maximum power	300W, focused beam ≥50μm, CW 500W, focused beam ≥100μm, CW
Detection time	≤1minute @500W
Parfocal tolerance (mm)	±0.5
Defocusing measurement range	-10mm~+5mm, calculated based on the parfocal distance of 95mm
Attenuator	OD4.5~OD8.5 (optional)
Communication interface	USB 3.0
External triggering	Available
Cooled method	Air cooled; Water cooled, flow 10L/min, water temperature 20~25°C, 0.5~ 1KW cooling capacity, pressure 10~25 meters
Operating environment	Temperature <0~35°C; Relative humidity <60%; Pointing test temperature: 15-25°C
Operating system	Windows 10/11; Optimum resolution: 1920*1080
Weight (kg)	<1.5

3. Microfocus Series



- Beam diameter range: 5um- 500um
- Output power up to 10W

Features:

- Spectral range: 248-266nm
- Beam diameter: 10μm~ 1mm
- Maximum power to 1W
- PC software

Specifications:

Model number	STC307UV-X5D-266
Spectral range (nm)	248-266
Min focus (μm)	10
Max focus (mm)	1
Magnification	5x
Detection precision (μm)	±1
Exposure time (ms)	0.05~500
Maximum power (W)	1
Attenuator	OD0-4 (optional)
Communication interface	USB3.0
External triggering	Available
Defocusing range (mm)	-1, +1.3
Operating environment	Temperature <0~35°C; Relative humidity<60% (Pointing test temperature: 15-25°C)
Operating system	Windows 10/11; Optimum resolution/1920*1080.
Weight (kg)	<1.5

Features:

- Spectral range: 248-266nm
- Beam diameter: 5 μ m~500 μ m
- Maximum power to 1W
- PC software

Specifications:

Model number	STC307UV-XD-266
Spectral range (nm)	248-266
Min focus (μ m)	5
Max focus (μ m)	500
Magnification	10x
Detection precision (μ m)	± 1
Exposure time (ms)	0.05~500
Maximum power (W)	2
Attenuator	OD0-4 (optional)
Communication interface	USB 3.0
External triggering	Available
Defocusing range (mm)	-1,+1.3
Operating environment	Temperature <0~35°C; Relative humidity <60% (Pointing test temperature: 15-25°C)
Operating system	Windows 10/11; Optimum resolution: 1920*1080
Weight (kg)	<1.5